



The ECO-4000 conveyor toaster is designed for long-life and high production. The conveyor handles products up to 1.5" thick such as bagels and English muffins and produces 350 slices per hour. The digital controls are easy to use and allow the operator control the top and bottom heating elements individually.

The ECO-4000 features a stainless steel construction with an aluminized steel interior. A heavy-duty motor and high temperature bearings that do not require lubrication make this toaster one of the most reliable on the market.

### WARRANTY

APW Wyott ECO-4000 toasters are backed by a 1-year parts and labor warranty.

### CERTIFICATIONS

Certified by the following agencies:



### FEATURES AT A GLANCE

- Toasts 350 slices per hour
- Consistent browning whether you insert one product or 100
- Toasts up to 1.5" thick products like bagels and English muffins
- All settings are factory preset but can be adjusted by removing control cover (4 screws)
- Individually controlled top and bottom heating elements
- Removable reflector tray for ease in cleaning
- Self-dispensing bread drawer slides forward for removal of product
- Stainless steel construction with aluminized steel interior provides durability
- (L) versions have power switch on the front; (E) versions have power switch on the back.
- Fully insulated with cool-to-the-touch sides
- Heavy duty motor, drive chain, and high-temperature bearings that do not need lubrication
- Air cooling system keeps critical components safe from heat
- High limit switch prevents toaster from over heating
- Conveyor belt is easy to access for daily cleaning
- Removable crumb trays

## EQUIPMENT DIMENSIONS

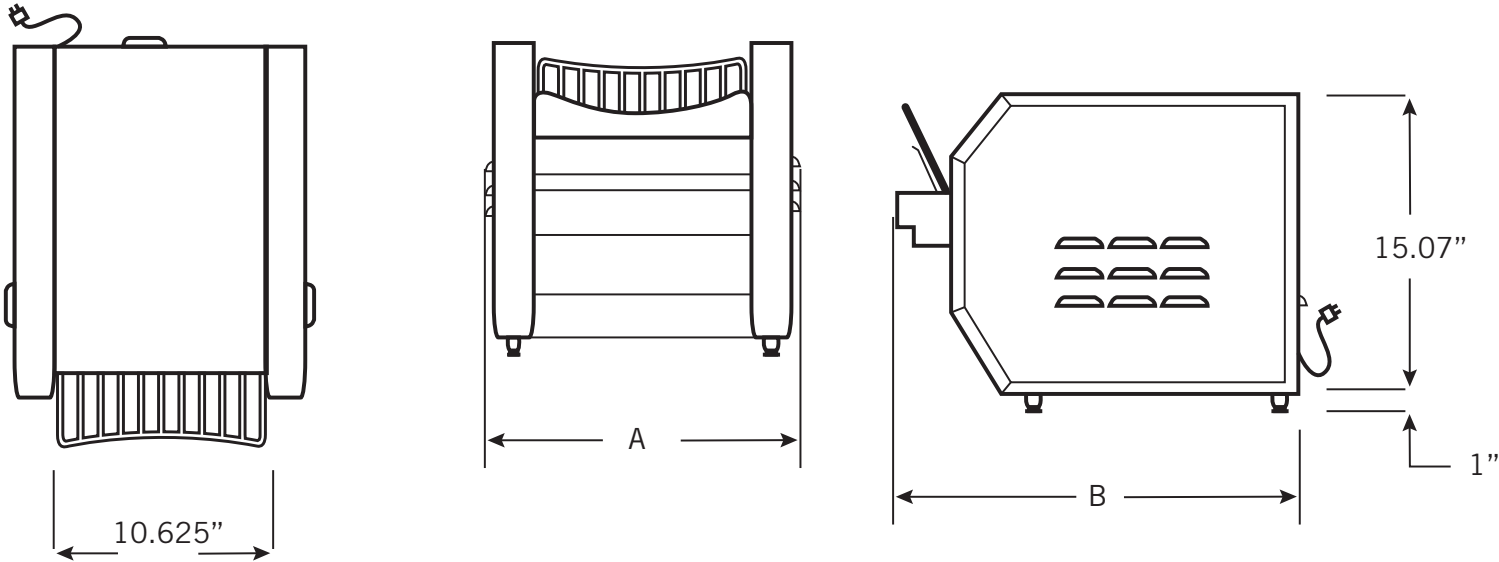

## MECHANICAL SPECIFICATIONS

Model #	Voltage	Watts	Phase	Amps	Overall Dimensions Width (A) x Height* x Depth (inches / mm)	Ship Weight (lbs. / Kilos)
ECO-4000 350E	120	1,725	1	14.2	14.84" x 16.06" x 23.5" (377 x 382.5 x 596.9)	54 lbs. (24.5 kg)
ECO-4000 350L	120	1,725	1	14.4	14.84" x 16.06" x 23.5" (377 x 382.5 x 596.9)	54 lbs. (24.5 kg)
ECO-4000 500E	208	2,800	1	13.5	14.84" x 16.06" x 23.5" (377 x 382.5 x 596.9)	54 lbs. (24.5 kg)
	240	2,800	1	11.7	14.84" x 16.06" x 23.5" (377 x 382.5 x 596.9)	54 lbs. (24.5 kg)
ECO-4000 500L	208	2,800	1	13.5	14.84" x 16.06" x 23.5" (377 x 382.5 x 596.9)	54 lbs. (24.5 kg)
	240	2,800	1	11.7	14.84" x 16.06" x 23.5" (377 x 382.5 x 596.9)	54 lbs. (24.5 kg)

E = Digital; L = Analog \*Height includes 1" legs.

## ELECTRICAL INFORMATION

Each unit is equipped with a 39", three wire grounded power cord which terminates with a NEMA 5-20P male plug on the 120V models, and NEMA 6-20P male plug on 208V and 240V models.

Freight Class: 100  
 FOB: Smithville, 37166

APW Wyott reserves the right to modify specifications or discontinue models without incurring obligation. Dimensions nominal.