

MODEL: BL66-F

FREEZER -10°

**GENERAL NOTE**

NOTICE TO GENERAL CONTRACTOR AND SUB-CONTRACTOR. UNIT QUARRY TILE OR CONCRETE WEARING FLOORS, THE METAL FACINGS MAY BE SUSCEPTIBLE TO STAINING DUE TO EXCESSIVE MOISTURE CREATED BY HYDRATION OF CONCRETE-TYPE MATERIALS. IT IS ESSENTIAL THAT EACH ROOM BE PROPERLY VENTILATED. SPECIAL PRECAUTIONS MUST BE TAKEN WHEN USING MURIATIC ACID DUE TO EFFECTS OF ACID FUMES ON ALUMINUM AND STAINLESS STEEL. IN ADDITION, METAL SURFACES MUST BE PROTECTED FROM LIME AND OTHER CHEMICALS FOUND IN CONCRETE BY-PRODUCTS. PETROLEUM BASED PROTECTION MUST BE APPLIED BETWEEN CONCRETE AND THE METAL SURFACES. (LIQUID TAR, BRUSHED OR SPRAYED ABOVE THE CONCRETE CONTACT LINE, HEAVY EPOXY PAINT, 8 MIL POLYETHYLENE H.D. BLACK DOUBLE LAYERED, 30 LB. ASPHALT IMPREGNATED ROOFING PAPER).

**CONSTRUCTION**

N.S.F. CONSTRUCTION

Project Name:  
ARCTIC INDUSTRIES, INC  
BLUE LINE

P.O.#:

APPLICATION:  
MODEL: BL66-F

**NOTES:**

FLOOR MUST BE LEVEL SMOOTH AND CLEAR OF OBSTRUCTIONS TO ACCEPT WALK-IN PANELS. ALSO, THERE MUST BE A MINIMUM OF 2' CLEARANCE AROUND ALL SIDES OF THE WALK-IN UNIT PROPER CIRCULATION.

VERIFY ALL DIMENSIONS AND SPECIFICATIONS BEUNITÉ APPROVING DRAWINGS

IMPORTANT: ALLOW 2 FEET CLEARANCE ABOVE UNIT TO REMOVE TOP PANEL AND TO ALLOW SERVICE ACCESS.

STRUCTURE MUST BE NOT MASKED TO BUILDING CEILING, BLOCKING AIR FLOW TO UNIT.

SIGNED APPROVED PRINT  
MUST BE REC'D. B/4 FAB.

APPROVED AS DRAWN

SIGNED \_\_\_\_\_

DATE: \_\_\_\_\_

Drawn By: R.PUPO

Checked By: ARCTIC

Scale: CREATED: 2014

NOT TO SCALE

DRW No:

B1007

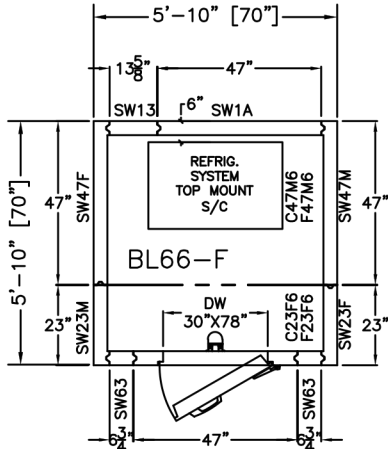

PLAN VIEW

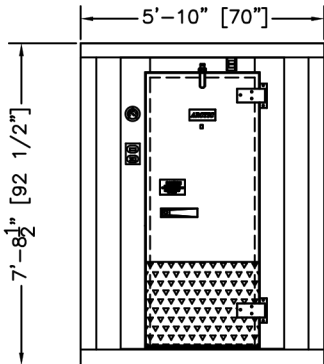

ELEVATION

SHOWN W/ RIGHT HINGE  
(LEFT HINGE AVAILABLE)

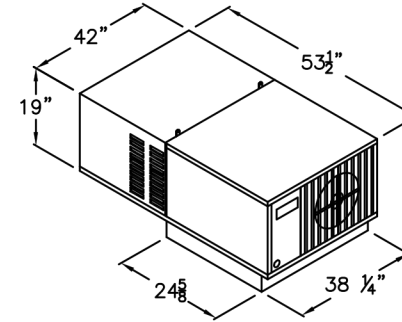
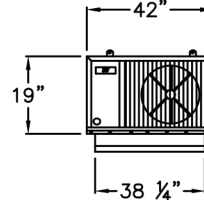

## REFRIGERATION UNIT

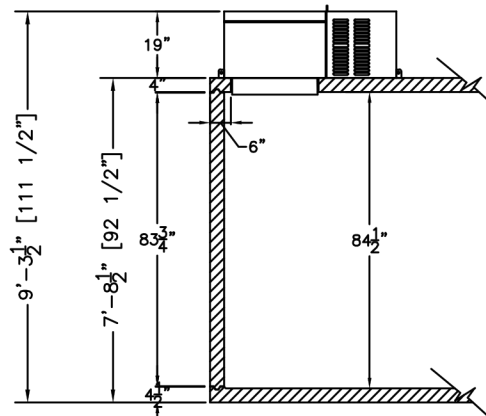

WALLS & TOP MOUNT  
S/C SECTION

PRODUCT SPECIFICATIONS	
MODEL:	BL66-F
INTERIOR/EXTERIOR FINISH	MILL EMB. ACRYLUME
INTERIOR FLOOR FINISH	SMOOTH ALUMINUM
COMPT ELECTRICAL (VOLTS/Hz/PH)	115/60/1
COMPT AMP.	2.0 Amp
REFRIG. SYSTEM ELECT (VOLTS/Hz/PH)	208-230/60/1
REFRIG. SYSTEM AMP.	18.1 Amp
CORD + NEMA 6-20R PLUG	
REFRIG. SYSTEM WEIGHT.	312 Lbs
TOTAL SHIP WGT APPROX. (2 PALLETS)	1188 Lbs
TOTAL SHIP CUBIC FEET APPROX.	237 CuFt



Energy Independence & Security Act