



# BEVERAGE-AIR

Project: \_\_\_\_\_

AIA#

Item: \_\_\_\_\_

Location: \_\_\_\_\_

SIS#

Approved: \_\_\_\_\_

## SPE FOOD PREPERATION TABLES

SPE36HC Sandwich Prep Table with Clear Lid  
Hydrocarbon Series

**MODELS:**  
**SPE36HC-08-CL**

SPE36HC Elite Series Sandwich Prep: Standard Top Series



**SPE36HC-08-CL**

**3 Year Parts/Labor Warranty**  
**Additional 2 Year Compressor Warranty**

### CABINET CONSTRUCTION

- Stainless steel front, sides, top, doors and grille (*galvanized back & bottom*)
- Interior liner is made of corrosion resistant aluminum
- Full electronic control
- Clear lift up lid
- Self-closing doors with 120° Stay-open feature, on cartridge style hinges
- Easy door removal for service and cleaning
- Field-reversible doors with snap-in door gaskets
- Painted aluminum door handles
- 6" Casters, 2 with brakes standard
- 10" Wide cutting board constructed of white polyethylene plastic
- Cutting board removable for cleaning
- Two epoxy-coated steel wire shelves per section standard
- Pans furnished are 4" deep constructed of polycarbonate plastic
- Enhanced airflow maintains temperature between 36° to 38°F

### OPTIONS & ACCESSORIES

- Stainless steel interior option
- Stainless steel back
- Remote options
- Drawers models
- Crumb catcher
- Modified pan openings
- Solid door with locks
- 6" Legs
- 3" Casters
- Low profile casters
- Richlite cutting board

### REFRIGERATION SYSTEM

- Refrigeration system uses R290 refrigerant to comply with all environmental concerns
- Recirculated, forced air from evaporator is moved under pans, which are recessed 2" from top of cabinet
- Automatic, non-electric evaporator
- System is serviceable from rear
- Epoxy coated evaporator coil



3779 Champion Blvd., Winston-Salem, NC 27105  
1-888-845-9800 Fax: 1-336-245-6453  
Beverage-Air.com sales@bevair.com



# BEVERAGE-AIR

## Food Preparation Table - Clear Lid

Models: SPE36HC-08-CL

MODEL	SPE36HC-08-CL
<b>EXTERNAL DIMENSIONAL DATA</b>	
Width Overall	36"
Depth Overall with Handle & Bumper	32"
Height Overall with 6" Casters with Lid Open	50 1/2"
Number of Doors	2
Depth with Door Open Extended	46 1/4"
Solid Door Opening (in)	13 3/4" x 21 7/8"
Depth, Cutting Board	10"
Shelf Area (sq. in.)	Upper 215 3/4" Lower 245 33/64"
<b>INTERNAL DIMENSIONAL DATA</b>	
NET Capacity (cubic ft.)	7.3
Internal Width Overall (in)	32"
Internal Depth Overall (in)	Upper 23 3/8" Lower 15 3/8"
Internal Height Overall (in)	23"
Internal Height Useable (in)	17 3/8"
Number of Shelves	4
Number of Pans	(8) 1/6
<b>ELECTRICAL DATA</b>	
Full Load Amperes 115/60/1	2
<b>REFRIGERATION DATA</b>	
Horsepower	1/6
Capacity (BTU/Hr)*	1140
<b>WEIGHT DATA</b>	
Gross Weight (Crated lbs)	250 lbs
Height - Crated	43"
Width - Crated	38"
Depth - Crated	33"

### Model Views

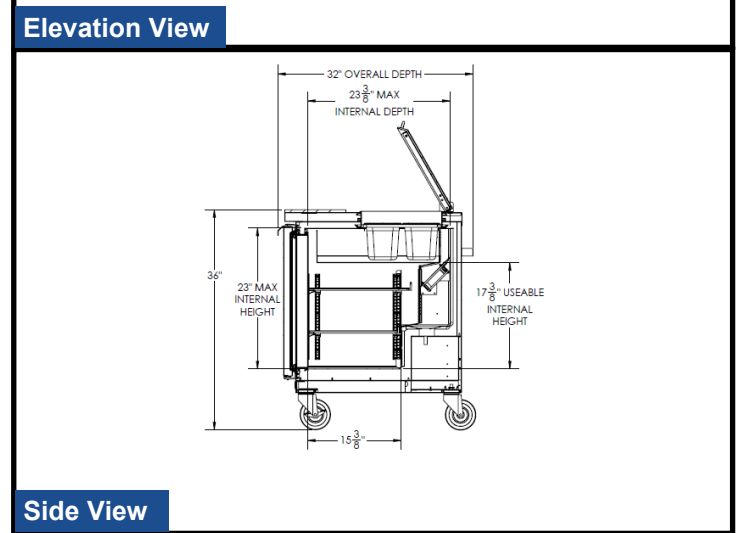
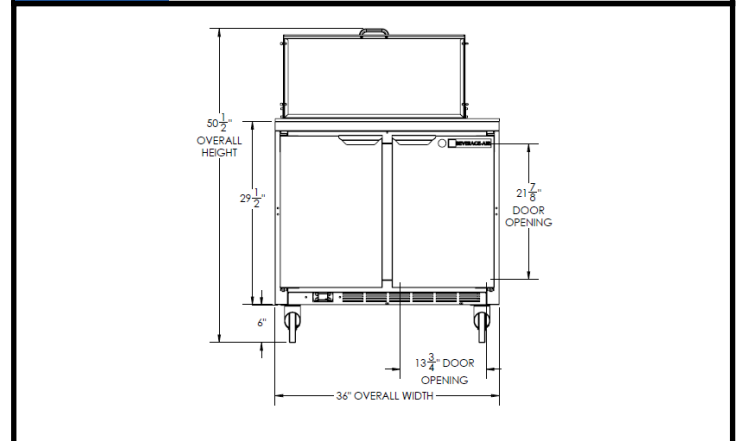
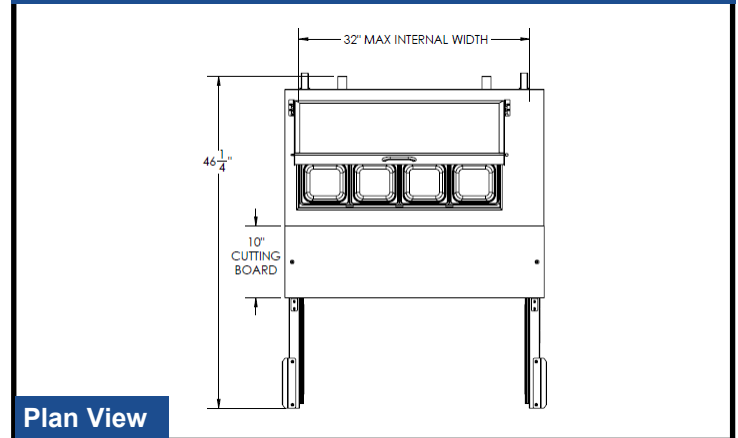

### ELECTRICAL CONNECTION



115/60/1  
NEMA-5-15P

Units pre-wired at factory and include 8' long cord and plug set.



an Ali Group Company



The Spirit of Excellence

3779 Champion Blvd., Winston-Salem, NC 27105  
1-888-845-9800 Fax: 1-336-245-6453  
Beverage-Air.com sales@bevair.com