



BLCT-62-62G

BLCT-62-62G

Full Size Double Gas
Boilerless Combination-Oven/Steamer
with Touchscreen Control



Project _____

Item No. _____

Quantity _____

- Standard rack with 3.35" (85mm) spacing holds ten full size sheet pans or twenty 12" x 20" x 2-1/2" deep North American hotel pans
- Optional rack with 2.56" (65mm) spacing holds twelve full size sheet pans or twenty-four 12" x 20" x 2" deep Gastronorm pans

Refer to operator manual specification chart for listed model names.

CONSTRUCTION

- 304 stainless steel exterior and interior
- Dual pane tempered viewing window with hinged inner glass for easy cleaning
- 2" (50mm) fixed drain in the bottom center of cavity
- Door mounted drip tray reduces the risk of wet, slippery floors
- Automatic door stops in positions 110° and 180° for ease of loading and unloading and improved safety.
- Left hinge door is field convertible to the right side (with the purchase of conversion kit)
- Two step safety door latch. The first step stops the fan.

OPERATION

- Injection steam system - water is injected onto the heating elements, the resulting steam is distributed in the oven chamber by the fan wheel.
- Easy to use touchscreen control
- Multiple cooking modes include hot air, CombiSmart, CombiOptima, retherm, steaming, low-temperature steaming, forced steaming, proofing, preheating
- Stores up to 500 recipes with up to 15 steps each
- Manual or automatic cooling
- Automatic humidity pulsing
- External core temperature probe
- Rack timing allows for setting individual timers for each rack
- Reversible 9 speed fan for optimum baking and roasting results
- USB port for data and recipe transfer
- HACCP recording and documentation
- Automated CombiWash, closed circuit cleaning system features very low water and detergent consumption and no contact with chemicals. No proprietary chemicals required, see owner's manual for detergent guidelines.

STANDARD FEATURES

- External core temperature probe with multiple measuring points. User-friendly location reduces strain on the probe
- 11-1/4" (285 mm) tall stand with casters
- Bright halogen lights for superior visibility
- Built in hand shower
- Removeable cleaning chemical bottle shelf
- 5 wire shelves per section
- Start-up inspection service by factory authorized service agent
- One year parts and labor oven warranty*

* For all international markets, contact your local distributor.

OPTIONS AND ACCESSORIES

(AT ADDITIONAL CHARGE)

- Side heat shield
- Wire oven rack
- Right hinge door
- Backflow preventer
- Extra year warranty

OPTIONS AND ACCESSORIES

(AT NO CHARGE)

- Optional rack with 2.56" (65mm) spacing
- Legs in lieu of casters



Intertek

BLODGETT OVEN COMPANY

www.blodgett.com • 42 Allen Martin Drive, Essex Junction, VT 05452 • Phone: (802) 658-6600 • Fax: (802) 864-0183



BLCT-62-62G



APPROVAL/STAMP

DIMENSIONS ARE IN INCHES (MM)

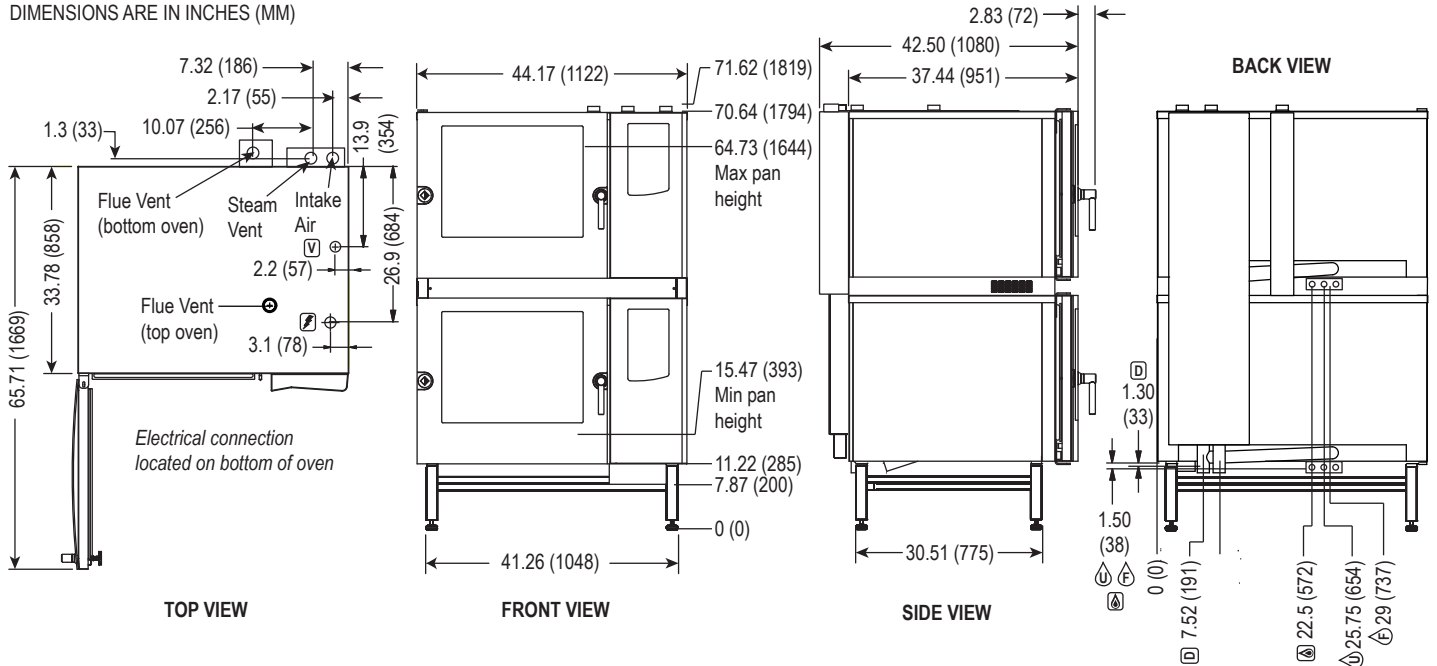

SHORT FORM SPECIFICATIONS: Provide Blodgett Combi model BLCT-62-62G combination-oven/steamer. The BLCT-62-62G has a rack with 3.35" (85mm) spacing that holds ten full size sheet pans or twenty 12" x 20" x 2-1/2" deep North American hotel pans. The optional rack with 2.5" (65mm) spacing holds twelve full size sheet pans or twenty-four 12" x 20" x 2" deep Gastronorm pans. Unit shall have 304 stainless steel exterior and interior. Oven door shall have dual pane tempered viewing window with hinged inner glass for easy cleaning. Unit shall have the ability to cook with pressureless steam, hot air, or combination of steam and hot air. Unit shall have steam injection system. Multiple modes include hot air, combi with CombiOptima, retherming, steaming, low-temperature steaming, forced steaming, proofing, cooling, and preheating. Unit shall have bright halogen lights for superior visibility. Touchscreen control stores 500 recipes with 15 stages each, in addition to pre-programmed recipes. External core temperature probe, rack timing allows for setting individual timers for each rack, HACCP quality control, USB connectivity, automatic service diagnosis. The reversible 9 speed fan provides optimum baking and roasting results. Automated CombiWash, closed circuit cleaning system features very low water and detergent consumption and no contact with chemicals. One-year parts and labor warranty. Provide start-up inspection service by a factory authorized service agent. Provide options and accessories as indicated.

DIMENSIONS:

Floor space: 44.17" x 37.44" (1122 x 951mm)
Unit height: 69.76" (1772mm)

OVEN CLEARANCES:

From combustible and non-combustible construction

Right 4" (102mm)
 Left 0" (0mm)
 Back 2" (50mm)

Blodgett recommends and 12" (305mm) be maintained on the control side for servicing.

MINIMUM ENTRY CLEARANCE:

Uncrated 33.78" (858mm)
 Crated 38" (965mm)

GAS SUPPLY (per section):

3/4" NPT

Inlet Pressure:

Natural 3.2-8.0" W.C. static to unit
 Propane 5.2-14" W.C. static to unit

Maximum Input:

81,800 BTU/hr

NOTE: The company reserves the right to make substitutions of components without prior notice.

POWER SUPPLY (per section):

115 VAC, 1 phase, 9 amps

Blodgett recommends a Pass & Seymour, model 2097, GFCI due to the use of a variable frequency drive. Must be hard wired in some cases.

WATER SUPPLY & DRAIN:

Good quality water feed is the responsibility of the owner. Water quality must be within the following general guidelines.

TDS: 40-125 ppm Hardness: 35-100 ppm pH: 7.0 - 8.5
 Silica: <13 ppm Chlorides: <25 ppm Chlorine: <0.2 ppm
 Chloramine: <0.2 ppm

The best defense against poor water quality is a water treatment system designed to meet your water quality conditions. Blodgett offers optional systems from Optipure.

Pressure: 40(min)-50(max) PSI

Connections: 2" drain connection - max. drain temperature 140°F (60°C)

3/4" garden hose cold water

The drain piping must consist of temperature resistant material, greater than 160°F, and be of adequate diameter not to cause flow restriction. Improper materials may deform and cause restrictions, thus affecting performance.

Appliance is to be installed with backflow protection in accordance with federal, state or local codes.

SHIPPING INFORMATION (per section):

Approx. weight: 925 lbs. (420 kg)