

# Ultra-2 HP BLK Manual Fill

32.0" x 24.5" x 16.0"  
(81.3cm x 62.2cm x 40.6cm)



 Servers and airpots sold separately

- Two large 3gal (11.4L) hoppers for optimum cooling and serving capacity
- Enhanced “no-lube” design on faucets and seals which simplifies installation and cleaning
- Full 2-year parts and 1-year labor warranty. 5-year parts and 1-year labor warranty on compressor and 3-year parts and labor warranty on electronics. See the product manual for additional details.
- Refrigeration system internally monitored to ensure long lasting performance
- Reversing auger design quickens freeze time and reduces air mixing
- Very simple to program and run with touchpad display, which also guides cleaning and preventive maintenance
- Sanitation listed by NSF to Standard 18 (includes dairy & alcohol)

Agency:



## Specifications

**Product #:** 34000.0080

**Water Access:** Not Plumbed

**Finish:** Black

**Hoppers:** Two

**Handle:** Extended Handle

## Additional Features

## Electrical & Capacity

Volts	Amps	Watts	Cord Attached	Plug Type	8oz cups/hr 236ml cups/hr	Input H <sub>2</sub> O Temp.	Phase	# Wires plus Ground	Hertz
120	12	1440	Yes	NEMA 5-15P	-	60°F (15.5°C)	1	2	50/60

## Plumbing Requirements

PSI	kPa	Fitting Supplied	Water Flow Required (GPM)
-	-	-	-

## CAD Drawings

2D	Revit	KLC
●		



BUNN® reserves the right to change specifications and product design without notice. Such revisions do not entitle the buyer to corresponding changes, improvements, additions or replacements for previously purchased equipment. For most current specifications and other info visit [bunn.com](http://bunn.com).

Created on:  
06/30/2017

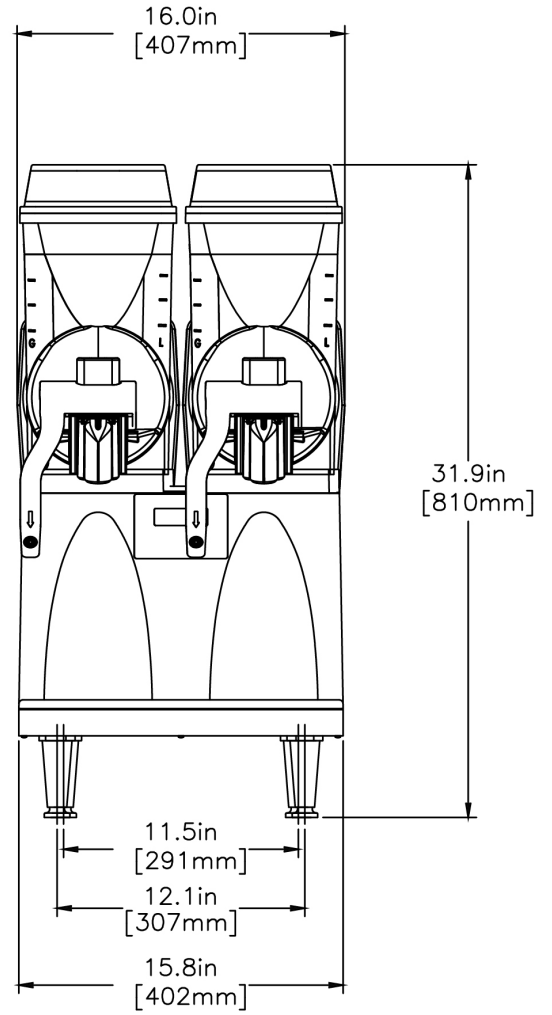
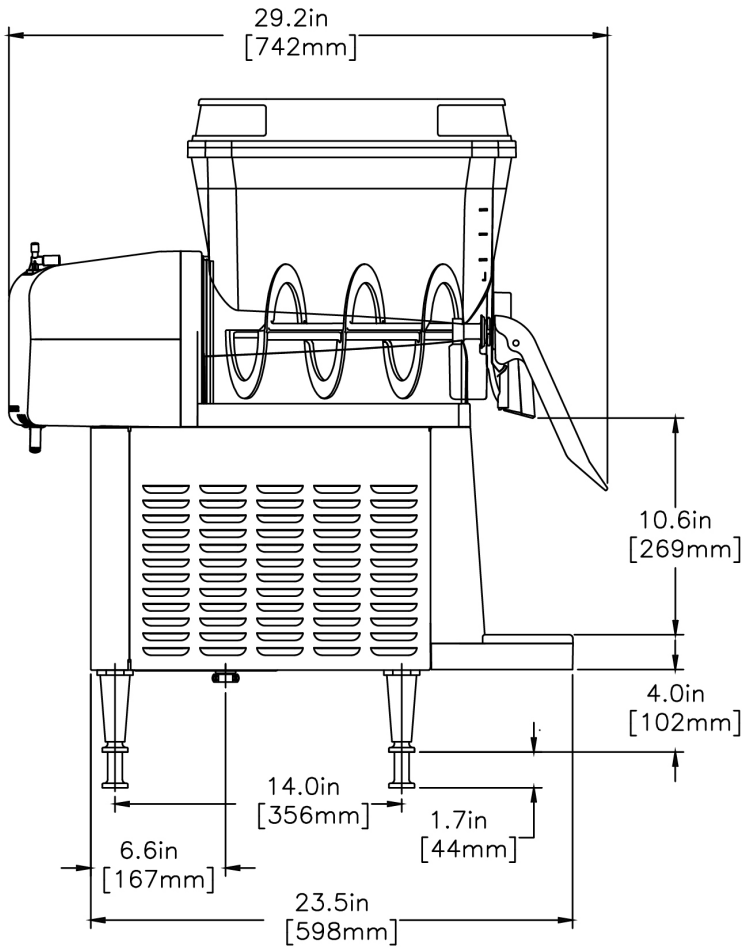
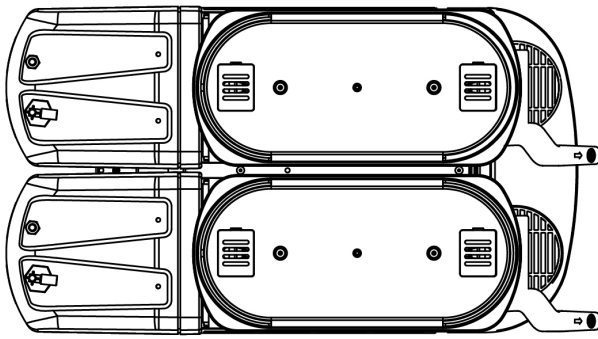

	Unit			Shipping				
	Width	Height	Depth	Width	Height	Depth	Weight	Volume
English	16.0 in.	32.0 in.	24.5 in.	-	-	-	137.260 lbs	-
Metric	40.6 cm	81.3 cm	62.2 cm	-	-	-	62.261 kgs	-



BUNN® reserves the right to change specifications and product design without notice. Such revisions do not entitle the buyer to corresponding changes, improvements, additions or replacements for previously purchased equipment. For most current specifications and other info visit [bunn.com](http://bunn.com).

Created on:  
06/30/2017

## Related Products & Accessories: Ultra-2 HP BLK Manual Fill(34000.0080)



DRIP TRAY ASSY,  
LOWER-BLK

Product #: 28086.0001



CHAROLA

Product #: 28086.0001

COVER, DRIP TRAY  
ULTRA 2 BLK

Product #: 32068.0001

ULTRA LAF KIT,SEP  
WATER LINES

Product #: 37960.0000

KIT, CFV UPGRADE W/  
HPRS ULTRA-2 BLK .035

Product #: 44071.0101



BUNN® reserves the right to change specifications and product design without notice. Such revisions do not entitle the buyer to corresponding changes, improvements, additions or replacements for previously purchased equipment. For most current specifications and other info visit [bunn.com](http://bunn.com).

Created on:  
06/30/2017