



# HIGH TEMPERATURE UNDERCOUNTER DISHWASHER GLASSWASHER

## 180UC-3

High Temperature Undercounter  
Dishwasher Glasswasher



### CMA MODEL: 180UC-3



Universal Pedestal  
(24"W X 25-3/8"D X 15-1/4"H)



6" and 4" Stainless Steel Legs



48" Undercounter Dishtable

### FEATURES

- Automatic fill.
- Energy Star 3.0 certified.
- The 2 minute timer includes the built-in, automatic Safe-T-Temp feature, which assures a 180°F sanitizing final rinse, every cycle.
- Top mounted controls are easy to read and simple to operate.
- Large 14-1/2" height clearance accommodates larger dishes, glasses and half size sheet pans.
- Upper and lower rotating wash and rinse arms blast water in all directions for optimum cleaning and rinsing.
- All stainless steel construction.
- Built-in booster heater.
- Built-in wash tank heater.
- Low water consumption. Uses only .68 gallons of water per cycle.
- Pumped drain.
- All Stainless Steel wash pump.
- Built in chemical dispensers with top mounted prime switches.
- Built in Delime switch.
- Stainless steel filters protect wash pump.
- 28 racks / 140 covers per hour.
- 1 Flat rack and 1 Peg rack included.

### AVAILABLE OPTIONS

- Drain Board
- Drain Water Tempering Kit





# 180UC-3

High Temperature Undercounter  
Dishwasher Glasswasher

**WARNINGS:**

- Electrical and Plumbing connections must be made by a qualified service provider who will comply with all available Federal, State, and Local Health, Electrical, Plumbing and Safety codes.
- CMA recommends utilizing a water softening system to maintain water hardness measurements of 3.5 gpg (grains per gallon) or less. This will assure maximum results and optimum operation of the dishwasher.

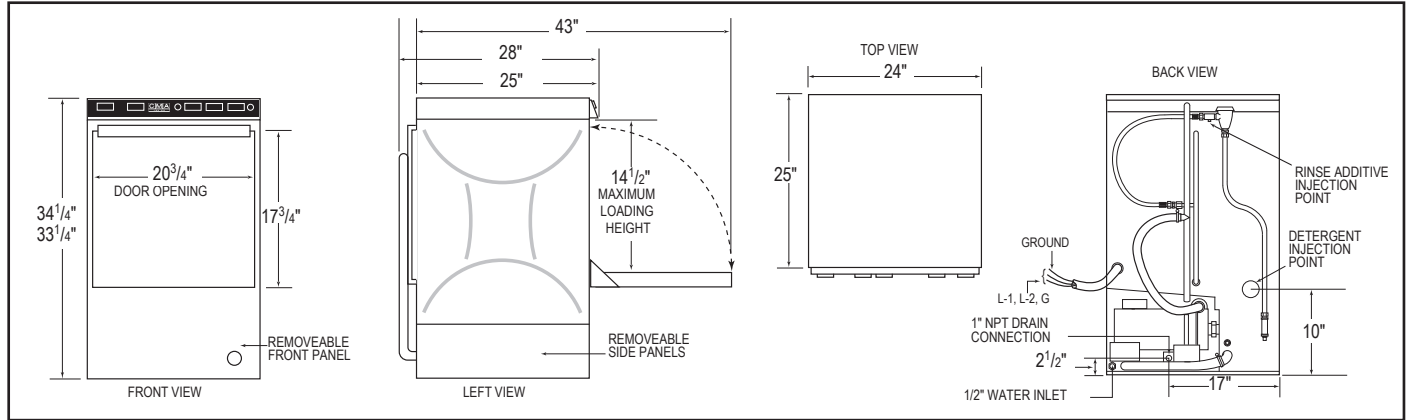

**Specifications:**

CMA 180UC-3	USA	(Metric)	CMA 180UC-3	USA	(Metric)
<b>WATER CONSUMPTION</b>			<b>FRAME DIMENSIONS</b>		
PER RACK	0.68 GAL.	(2.57 L)	DEPTH	25"	(63.5 CM)
PER HOUR	19.0 GAL.	(72.1 L)	WIDTH	24"	(60.96 CM)
<b>OPERATING CYCLE</b>			HEIGHT	33-1/4"	(84.45 CM)
WASH TIME-SEC	99	99	MAX CLEARANCE FOR DISHES	14-1/2"	(36.8 CM)
RINSE TIME-SEC	11	11	<b>WASH PUMP MOTOR</b> 3/4 HP 3/4 HP		
DWELL TIME-SEC	10	10	<b>ELECTRICAL RATING</b>		
TOTAL CYCLE TIME	2 MIN.	2 MIN.	208 VOLTS	240 VOLTS	
<b>OPERATING CAPACITY</b>			1 PH-60 Hz	1 PH-60 Hz	
RACKS PER HOUR **	28	28	TOTAL AMPS	30.0 AMPS	32.0 AMPS
WASH TANK CAPACITY	2.5 GAL.	(9.46 L)	BOOSTER HEATER KW	5.3 kW	6.5 kW
PUMP CAPACITY	38 GPM	(144 LPM)	WASH HEATER KW	2.2 kW	2.9 kW
<b>WATER REQUIREMENTS</b>			THIS SYSTEM REQUIRES TWO POWER WIRES (SUPPLIED BY CMA) NO NEUTRAL WIRE NEEDED. AN ADDITIONAL THIRD WIRE MUST BE PROVIDED FOR MACHINE GROUND.		
REQUIRED MINIMUM TEMP.	120°F	(43°C)			
RECOMMENDED TEMP.*	140°F	(60°C)			
WATER INLET	1/2"	(1.27 CM)			
DRAIN CONNECTION	1"	(2.54 CM)			
RINSE PRESSURE SET	20 ±5PSI	1.41 KG/CM²	<b>APPROXIMATE SHIPPING WEIGHT</b> 234# 106 kg		
<b>CYCLE TEMPERATURES</b>			<b>SHIPPING DIMENSIONS</b> PALLET & BOX @ 29" X 28" X 41"		
WASH-°F	160° F Minimum	(70°C)			
RINSE-°F	180° F-195° F	(82°C/90°C)			

**Summary Specifications: CMA180UC-3**

The CMA Dishmachines model CMA 180UC-3 undercounter dishwasher/glasswasher provides hot water (180°F) sanitizing through the use of a built-in booster heater. 180°F final rinse Safe-T-Temp system ensures proper temperatures in the final rinse by holding wash cycle in run mode until 180°F rinse temperature is detected. The unit comes standard with upper and lower stainless steel wash and final rinse arms, digital LED temperature gauges and easy to operate controls. The CMA 180UC-3 is constructed entirely of stainless steel. Uses standard 20"x20" dishracks and accommodates oversized plates, glasses and utensils with 14-1/2" door clearance.

**Advisory:** CMA does NOT endorse "Tankless On-Demand" water heaters for use on CMA Dishmachine products. CMA DOES endorse, and highly recommends, the standard "tank" style water heaters, sized properly to handle each particular facility with their water heating requirements.

**\*For faster heat recovery \*\*Plus 7 second load time**



CMA Dishmachines 17707 Valley View Ave; Cerritos, CA 90703 • 800-854-6417 • 714-898-8781 • Fax: 714-895-2141 • www.cmadishmachines.com

CMA reserves the right to modify specifications or discontinue models without prior notification.

© 09-2024 CMA, Inc.

