

DESIGNER LINE UNDERCOUNTER FREEZER (0°F)

Model: DLF27-SS-U-D

27" Undercounter Freezer
with Drawers

Stainless steel front, top, end panels and interior, aluminum back.

Designed to maintain NSF-7 temperatures in 100°F ambient.



Options and Accessories

(upcharge and lead times may apply)

Stainless steel back	Drawer locks
Solid door in lieu of drawers	Special electrical requirements (<i>consult factory</i>)
Glass door in lieu of drawers	

Consult factory for other model configurations, options and accessories.

Project Name:

Model Specified:

Location:

Item No:

Quantity:

AIA #:

SIS #:

Standard Model Features

REFRIGERATION SYSTEM

- Performance-rated refrigeration system
- Environmentally-safe R-290 refrigerant
- Automatic, hot gas condensate evaporator
- Non-corrosive, plasticized fin evaporator coil
- Easily serviceable back mounted compressor

CABINET ARCHITECTURE

- 2" non-CFC polyurethane foam insulation
- Stainless steel roll-out drawers
- Magnetic snap-in drawer gaskets
- Completely enclosed, vented and removable case back
- 1 3/8" diameter plate casters (factory installed)

MODEL FEATURES

- Electronic controller w/ digital display & hi low alarm
- 2" high, bottom mounted front breather air divider
- Automatic electric defrost

Front breathers are a unique bottom mounted ventilation system designed to allow cabinets to be flush against a wall or built into a counter to conserve space.

Continental
Refrigerator

Toll-Free: 800-523-7138
Phone: 215-244-1400
Fax: 215-244-9579

539 Dunksferry Road
Bensalem, PA 19020
www.continentalrefrigerator.com

APPROVAL:

Model Specifications

DIMENSIONAL DATA

Net Capacity (cu. ft.)	7.4 (210 cu l)
Width, Overall (in.)	27 1/2 (699 mm)
Depth, Overall (in.) (incl. handles & bumpers)	31 9/16 (802 mm)
Height, Overall (in.) (incl. 1 3/8" plate casters)	31 13/16 (808 mm)
No. of Drawers (two tier)	2
No. of Drawers (three tier)	3

REFRIGERANT DATA

Condensing Unit Size (H.P.)	1/4
Capacity (BTU/Hr)*	1572

ELECTRICAL DATA

Voltage (int'l)	115/60/1 (n/a)
Fans	1
Total Amps (int'l)	4.0 (2.8)
Defrost Amps (int'l)	4.8 (2.4)
10 ft. Cord/Plug [attached] (int'l)	Yes (No)

SHIPPING DATA

Weight (lbs.)	165 (75 kg)
Height - Crated (in.)	43 1/4 (1099 mm)
Width - Crated (in.)	35 3/4 (908 mm)
Depth - Crated (in.)	37 1/4 (946 mm)

DRAWER PAN CONFIGURATIONS

Two Tier: (1) 12 x 20 x 6 pan per drawer

Three Tier: (1) 12 x 20 x 4 pan per drawer

* Rating @ -15°F evaporator, 90°F ambient

Figures in parentheses reflect metric equivalents rounded to the nearest whole unit.



Equipped with one NEMA-5-15P Plug
(varies by country)

Continental
Refrigerator

Toll-Free: 800-523-7138
Phone: 215-244-1400
Fax: 215-244-9579

539 Dunksferry Road
Bensalem, PA 19020
www.continentalrefrigerator.com

Due to our continued efforts in developing innovative products, specifications subject to change without notice.



MADE IN THE U.S.A.

© Copyright 2017. Continental Refrigerator.
A Division of National Refrigeration & Air Conditioning Products, Inc.

Model Plan Views

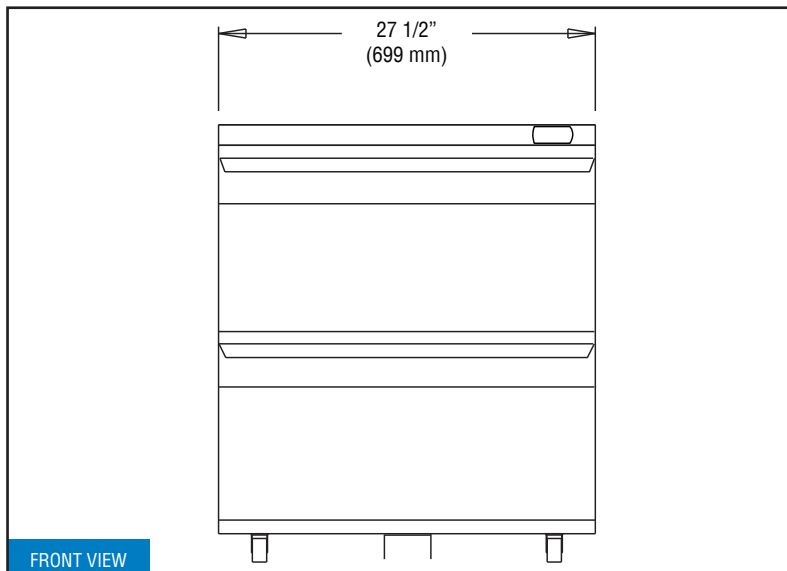

FRONT VIEW

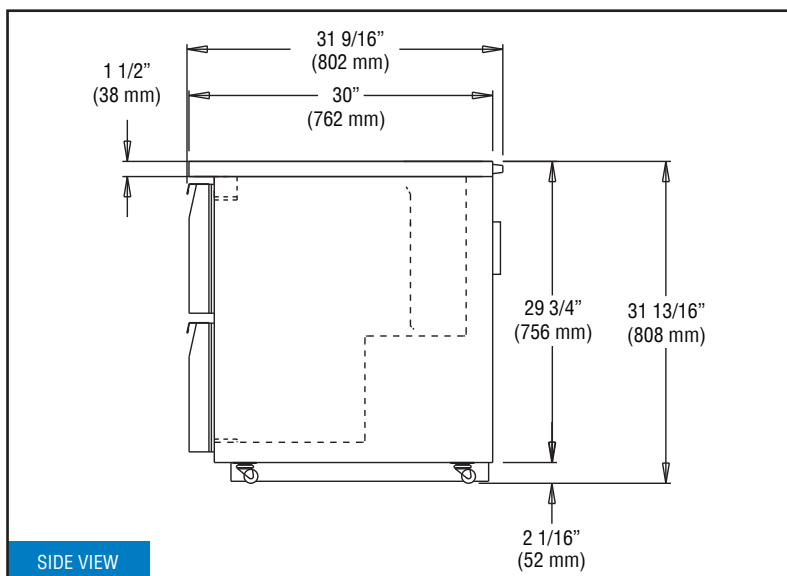

SIDE VIEW

NOTE: For proper operation, the area under and in front of the cabinet **must** not be obstructed in any way.

REFRIGERATION SYSTEM

The self-contained refrigeration system is rear mounted, concealed behind a removable back cover. Bottom mounted, low profile air divider allows for even air circulation to condensing unit. A "performance-rated", air-cooled, hermetically sealed, capillary type refrigeration system is installed in model. Plasticized finned coil and air circulating fans are contained within an easily accessible rear mounted housing. Unique airflow design allows the cabinet to be enclosed on both sides or mounted flush against a wall. Refrigeration system, fully charged with R-290 refrigerant, is designed to maintain 0°F while operating with an unrestricted air supply in an ambient temperature of 100°F. All condensate water is directed to a hot gas condensate vaporizer located in the compressor compartment, no plumbing is required. A strict quality assurance team inspects all materials and components to certify the model conforms to the most exacting standards. Model is performance tested for a minimum of 16 hours prior to crating.

INSULATION

All cabinet walls, top and bottom have high density, foamed-in-place, non-CFC polyurethane insulation.

CABINET CONSTRUCTION

Materials are of top quality and are assembled under rigid supervision conforming to strict quality assurance requirements. Cabinet is internally supported and braced for rigid unit construction. Cabinet front, top, end panels and interior are all stainless steel. Cabinet design eliminates overlapping panels with raw edges. Interior corners are rounded with a 1/4" radius for cleaning ease.

DRAWER CONSTRUCTION

Front/back are constructed of heavy-gauge, polished stainless steel with heavy-duty, safety grip, chrome-plated handles. Drawer fronts are insulated with non-CFC polyurethane foam insulation. Full extension, lift-out frames are heavy gauge, welded stainless steel mounted on heavy-duty, easy glide, self-closing slides. Self-adjusting, full perimeter, magnetic snap-in gaskets guarantee a positive seal.