

# DESIGNER LINE WARMER

**Model: DL2W-PT**

## 2-Section Pass-Thru Warmer

DL2W-PT - Stainless steel front, aluminum end panels and interior  
 DL2W-SA-PT - Stainless steel exterior, aluminum interior  
 DL2W-SS-PT - Stainless steel exterior and interior  
**Designed to maintain NSF-7 temperatures in 100°F ambient.**



### Options and Accessories

(upcharge and lead times may apply)

Stainless steel case back	Glass doors
Add'l chrome-plated steel shelves	Special electrical req. (consult factory)
Stainless steel shelves	<b>Correctional Facility Options</b>
Rehinging of doors (consult factory)	• One way security screws
Pan slide assemblies	• Locking hasp (lock not included)
Casters	• Stainless steel mesh cover
Custom laminates	• Coverless hinges
Half doors	

Consult factory for other model configurations, options and accessories.



Toll-Free: 800-523-7138  
 Phone: 215-244-1400  
 Fax: 215-244-9579

539 Dunksferry Road  
 Bensalem, PA 19020  
[www.continentalrefrigerator.com](http://www.continentalrefrigerator.com)

Project Name:

Model Specified:

Location:

Item No:

Quantity:

AIA #:

SIS #:

### Standard Model Features

#### HEATING SYSTEM

Self contained, performance-rated heating system  
 90°F to 180°F temperature range  
 Top mounted heating plenum "plug" w/circulating fan  
 Humidity relief vent  
 Unique air flow distribution ducts

#### CABINET ARCHITECTURE

3" non-CFC polyurethane foam insulation  
 Smooth, polished chrome workflow door handles  
 Cam action, lift off hinges  
 Self-closing doors  
 Magnetic snap-in door gaskets  
 Cylinder lock in each door  
 Heavy-duty, chrome-plated steel shelves  
 Adjustable 6" stainless steel legs

#### MODEL FEATURES

Automatic interior lighting  
 Electronic controller w/ digital display & hi-low alarm  
 Stainless steel strip heaters located in base of interior

APPROVAL:

## Model Specifications

### DIMENSIONAL DATA

Net Capacity (cu. ft.)	50 (1416 cu l)
Width, Overall (in.)	52 (1321 mm)
Depth, Overall (in.) (incl. handles)	38 3/4 (984 mm)
Depth [less doors] (in.)	32 (813 mm)
Depth [doors open 90°] (in.)	79 (2007 mm)
Clear Door Width (in.)	19 3/8 (492 mm)
Clear Door Height (in.)	58 5/8 (1489 mm)
Height, Overall (in.) (incl. 6" legs)	83 1/4 (2115 mm)
No. of Doors	4
No. of Shelves	6
Shelf Area (sq. ft.)	40.8 (3.8 sq m)
Tray Slide Capacity (per section)	19

### ELECTRICAL DATA

Voltage	208-230/60/1
Feed Wires (incl. ground)	3
Total Amps (int'l)	10.6 (10.6)
Total Wattage @ 208-230 volts	2250
10 ft. Cord/Plug (int'l)	No (No)

### SHIPPING DATA

Height - Crated (in.)	85 1/2 (2172 mm)
Width - Crated (in.)	64 (1626 mm)
Depth - Crated (in.)	42 (1067 mm)
Volume - Crated (cu. ft.)	133 (3766 cu l)
Weight Std - Crated (lbs.)	433 (196 kg)
Weight SS - Crated (lbs.)	455 (206 kg)

Figures in parentheses reflect metric equivalents rounded to the nearest whole unit.

## Model Plan Views

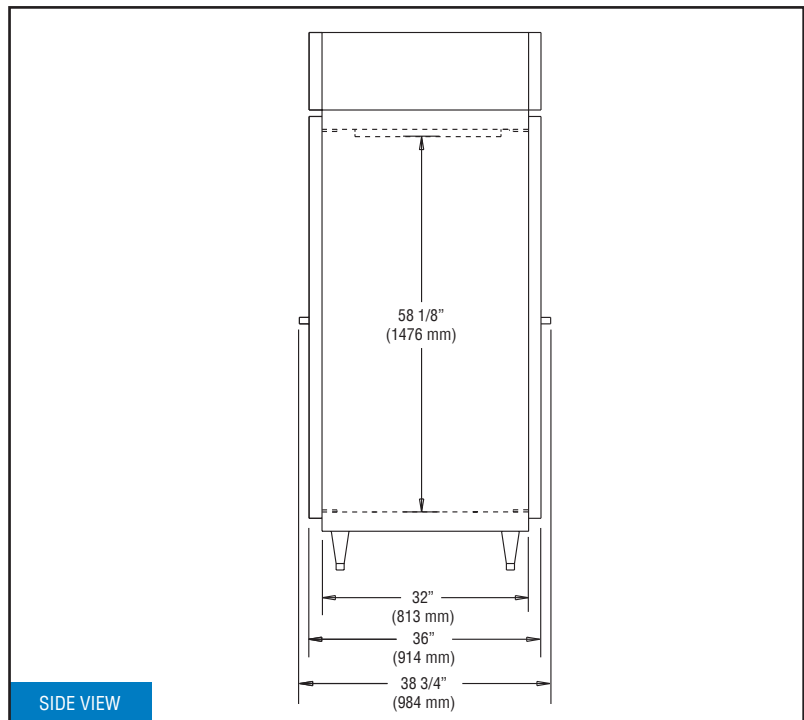
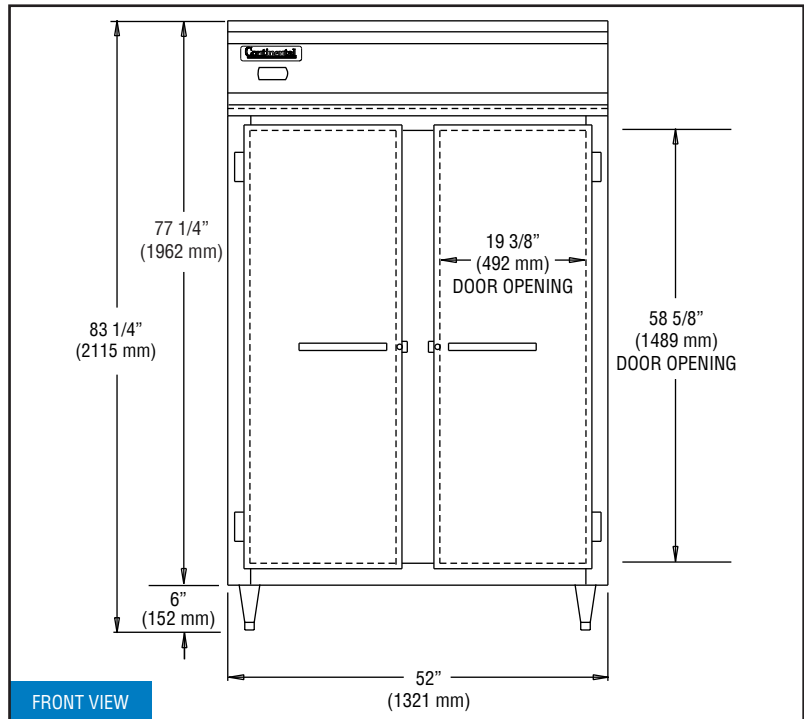

**IMPORTANT NOTE:** If the cabinet is located directly against a wall and/or under a low ceiling, a minimum clearance of 12" is required on top and 3" on sides and rear.

**Continental**  
Refrigerator

Toll-Free: 800-523-7138  
Phone: 215-244-1400  
Fax: 215-244-9579

539 Dunkserry Road  
Bensalem, PA 19020  
[www.continentalrefrigerator.com](http://www.continentalrefrigerator.com)

Due to our continued efforts in developing innovative products, specifications subject to change without notice.



Intertek



MADE IN THE U.S.A.

© Copyright 2018. Continental Refrigerator.  
A Division of National Refrigeration & Air Conditioning Products, Inc.