

DESIGNER LINE FISH FILE

Model: DLRA43-SS-F

43" Fish File Base

Specially designed for the storage of fresh fish packed in crushed ice in drawer pans supplied with unit.

#300 Series stainless interior, stainless steel exterior.

Designed to maintain NSF-7 temperatures in 100°F ambient.



Options and Accessories

(upcharge and lead times may apply)

Stainless steel back	Door/drawer locks
Overshelves (single or double)	Casters
Drawer in lieu of half door above the condensing unit*	Front breathing
Automatic, electric condensate evaporator	Special electrical requirements (<i>consult factory</i>)
Condensing unit left or right	Backsplash

*Drawer section above condensing unit holds (1) 12 x 20 x 6 pan (not supplied). This section is not set up for fish storage.

Continental
Refrigerator

Toll-Free: 800-523-7138
Phone: 215-244-1400
Fax: 215-244-9579

539 Dunksferry Road
Bensalem, PA 19020
www.continentalrefrigerator.com

Project Name:

Model Specified:

Location:

Item No:

Quantity:

AIA #:

SIS #:

Standard Model Features

REFRIGERATION SYSTEM

Performance-rated refrigeration system

Environmentally-safe R-134a refrigerant

Unique forced air design utilizes fans (approx. every 12") across the entire back of unit for even distribution of cold

Automatic, energy saving, non-electric condensate evaporator

Non-corrosive, plasticized fin evaporator coil

Easily serviceable, slide-out condensing unit

CABINET ARCHITECTURE

2" non-CFC polyurethane foam insulation

Spring loaded, self closing door (above condensing unit)

Magnetic snap-in door/drawer gaskets

Stainless steel, easy glide roll-out drawers on heavy-duty drawer track

Refrigerated section with door above the condensing unit

Adjustable 6" stainless steel legs

MODEL FEATURES

Electronic controller w/digital display & hi-low alarm

1" diameter cleanout drain (requires provisions for floor drain)

Fully welded, non-corrosive stainless steel pan per drawer w/built-in drain tubes and ice grates (drain into gutter)*

Expansion valve for quick recovery

Built-in, off-cycle defrost timer

Field rehingeable door (above condensing unit)

* Each drawer has a removable pan, with a drain tube at the back corner. Water from melting ice in the pan, along with moisture from the product, drains out of the storage pan through the tube, along a trough on the interior cabinet wall, down the sloped interior bottom, and out of the cabinet through a 1" drain tube.

NOTE: DLRA-F models come standard with a door over the condensing unit. A drawer over the condensing unit is an option. **This section is not set up for fish storage.**

APPROVAL:

Model Specifications

DIMENSIONAL DATA

Net Capacity (cu. ft.)	12 (340 cu l)
Width, Overall (in.)	43 (1092 mm)
Depth, Overall (in.) (incl. handles & bumpers)	36 1/16 (916 mm)
Height, Overall (in.) (incl. 6" legs)	36 (914 mm)
No. of Drawers	2
No. of Half Doors	1
Interior Depth (in.) (above condenser)	30 (762 mm)
Interior Height (in.) (above condenser)	12 1/2 (318 mm)
Interior Width (in.) (above condenser)	17 (432 mm)

REFRIGERANT DATA

Condensing Unit Size (H.P.)	1/3
Capacity (BTU/Hr)*	2610

ELECTRICAL DATA

Voltage (int'l)	115/60/1 (220/50/1)
Fans	2
Total Amps (int'l)	6.0 (2.9)
10 ft. Cord/Plug [attached] (int'l)	Yes (No)

SHIPPING DATA

Weight (lbs.)	355 (161 kg)
Height - Crated (in.)	43 3/4 (1111 mm)
Width - Crated (in.)	45 (1143 mm)
Depth - Crated (in.)	47 (1194 mm)

DRAWER PAN CONFIGURATIONS

(1) 20 5/32 x 17 3/4 x 6 pan per drawer
(can accommodate 12 x 20 perforated pans)

* Rating @ +25°F evaporator, 90°F ambient

Figures in parentheses reflect metric equivalents rounded to the nearest whole unit.



Equipped with one NEMA-5-15P Plug
(varies by country)

Continental
Refrigerator

Toll-Free: 800-523-7138
Phone: 215-244-1400
Fax: 215-244-9579

539 Dunkserry Road
Bensalem, PA 19020
www.continentalrefrigerator.com

Due to our continued efforts in developing innovative products, specifications subject to change without notice.



MADE IN THE U.S.A.

© Copyright 2018. Continental Refrigerator.
A Division of National Refrigeration & Air Conditioning Products, Inc.

Model Plan Views

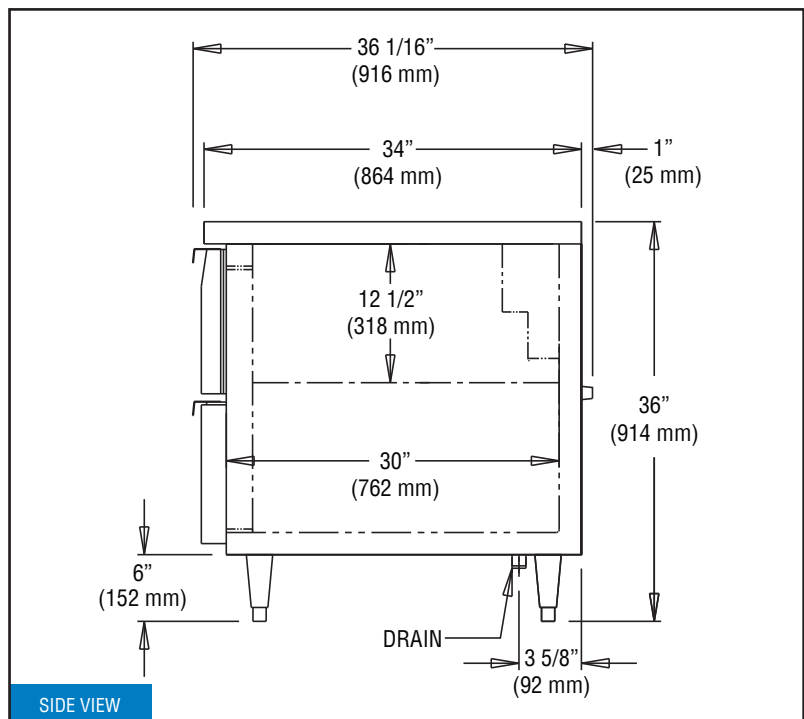
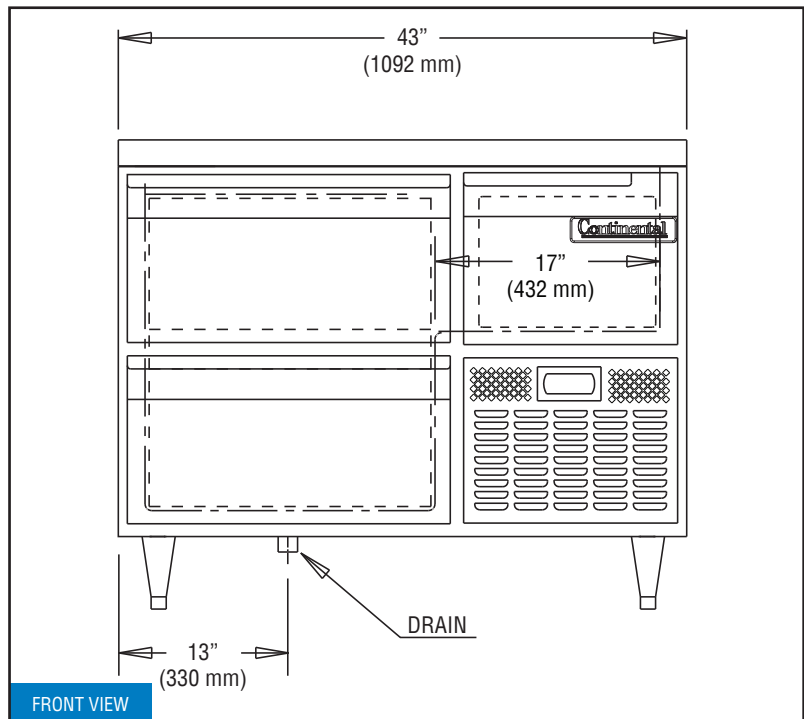

IMPORTANT NOTE: If the cabinet is located directly against a wall, a minimum clearance of 3" is required on sides, front and rear. 1" NPS Drain Tube must be directly piped to a building floor drain or connected to a suitable waste line.