

BASE UNDERCOUNTER FREEZER (0°F)

Model: CFA43-U-D

43" Base Undercounter Freezer with Drawers

Heavy gauge #300 Series stainless steel top, stainless steel front and end panels, galvanized steel rear and grill and aluminum interior.

Designed to maintain NSF-7 temperatures in 100°F ambient.



Options and Accessories

(upcharge and lead times may apply)

Stainless steel interior	Condensing unit left or right
Stainless steel back	Automatic, electric condensate evaporator
Door in lieu of drawers	Door/drawer locks
Drawer in lieu of half door above the condensing unit	Special electrical requirements (consult factory)

*Drawer section above condensing unit holds (1) 12 x 20 x 6 pan

Project Name:

Model Specified:

Location:

Item No:

Quantity:

AIA #:

SIS #:

Standard Model Features

REFRIGERATION SYSTEM

Performance-rated refrigeration system

Environmentally-safe R-404A refrigerant

Unique forced air design utilizes fans (approx. every 12") across the entire back of unit for even distribution of cold

Automatic, energy saving, non-electric condensate evaporator

Non-corrosive, plasticized fin evaporator coil

Easily serviceable, slide-out condensing unit

CABINET ARCHITECTURE

2" non-CFC polyurethane foam insulation

Spring loaded, self closing door (over condensing unit)

Magnetic snap-in door/drawer gaskets

Stainless steel roll-out drawers

Completely enclosed, vented and removable rear and side grills

Refrigerated section with door above the condensing unit

(8) 1 3/8" diameter plate casters mounted on heavy-duty support plates (easily field installed)

MODEL FEATURES

Electronic controller w/ digital display & hi-low alarm

Front breather air divider (field installed)

Expansion valve for quick recovery

Automatic electric defrost

NOTE: CFA-U models come standard with a door over the condensing unit. A drawer over the condensing unit is an option.

Continental
Refrigerator

Toll-Free: 800-523-7138
Phone: 215-244-1400
Fax: 215-244-9579

539 Dunksferry Road
Bensalem, PA 19020
www.continentalrefrigerator.com

APPROVAL:

Model Specifications

DIMENSIONAL DATA

Net Capacity (cu. ft.)	12 (340 cu l)
Width, Overall (in.)	43 (1092 mm)
Depth, Overall (in.) (incl. handles & bumpers)	36 1/16 (916 mm)
Height, Overall (in.) (incl. 1 3/8" plate casters)	31 3/4 (806 mm)
No. of Drawers	2
No. of Half Doors	1
Interior Depth (in.) (above condenser)	30 (762 mm)
Interior Height (in.) (above condenser)	12 1/2 (318 mm)
Interior Width (in.) (above condenser)	17 (432 mm)

REFRIGERANT DATA

Condensing Unit Size (H.P.)	1/3
Capacity (BTU/Hr)*	1340

ELECTRICAL DATA

Voltage (int'l)	115/60/1 (220/50/1)
Fans	2
Total Amps (int'l)	6.1 (3.7)
10 ft. Cord/Plug [attached] (int'l)	Yes (No)

SHIPPING DATA

Weight (lbs.)	340 (154 kg)
Height - Crated (in.)	43 3/4 (1111 mm)
Width - Crated (in.)	45 (1143 mm)
Depth - Crated (in.)	47 (1194 mm)

DRAWER PAN CONFIGURATIONS

Two Tier: (2) 12 x 20 x 4 pans (top)
and (2) 12 x 20 x 6 pans (bottom)

Three Tier: (1) 12 x 20 x 4 pan (top)
and (2) 12 x 20 x 4 pans per drawer (center & bottom)

* Rating @ -15°F evaporator, 90°F ambient

Figures in parentheses reflect metric equivalents rounded to the nearest whole unit.



Equipped with one NEMA-5-15P Plug
(varies by country)

Model Plan Views

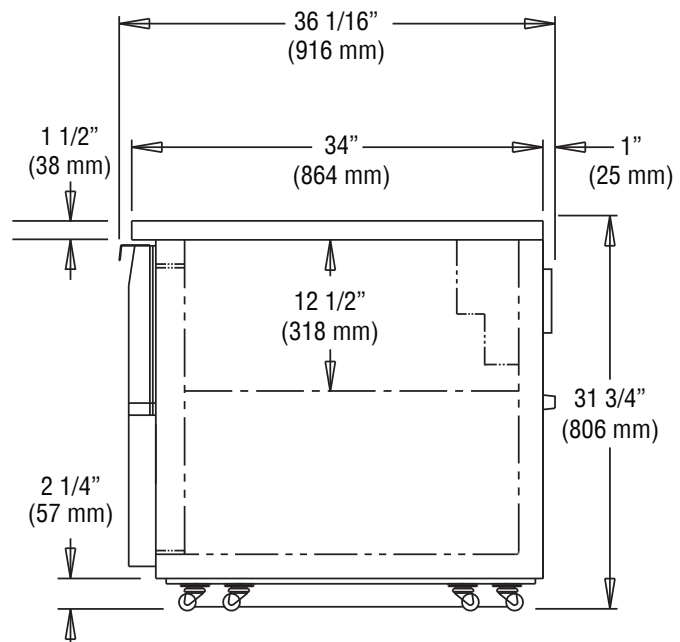
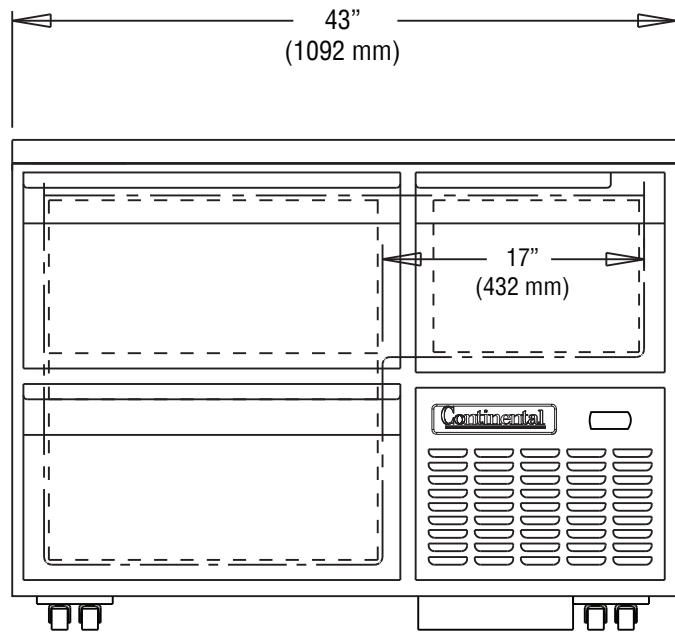

Continental
Refrigerator

Toll-Free: 800-523-7138
Phone: 215-244-1400
Fax: 215-244-9579

539 Dunkserry Road
Bensalem, PA 19020
www.continentalrefrigerator.com

Due to our continued efforts in developing innovative products, specifications subject to change without notice.



MADE IN THE U.S.A.

© Copyright 2017, Continental Refrigerator.
A Division of National Refrigeration & Air Conditioning Products, Inc.