



**a Standex company**

ITEM: \_\_\_\_\_ PROJECT NAME: \_\_\_\_\_ DATE: \_\_\_\_\_

## WALL DISPLAY NON-REFRIG. SELF-SERVE BAKERY CASE

MODEL  WDC-42



*Generate increased impulse sales with maximum product exposure.*

### STANDARD FEATURES

- Tempered self-closing full view front service doors.
- Glass ends and top.
- All-welded base and frame construction with a choice of six standard laminates on base and counter top. Satin finish stainless steel trim. Other color laminates optional.
- Four adjustable white epoxy coated slanted wire shelves.
- Mirrored back panel.
- Base storage area with solid sliding doors.
- Bag bin with three dividers.
- Counter top with tissue holder (5 3/4" x 6 1/2" x 2 1/2").
- Sloped front providing high visual product display.

# WALL DISPLAY NON-REFRIGERATED SELF-SERVE BAKERY CASE

## OPTIONAL ACCESSORIES:

- Special Base Finish
- Vertical LED lights (includes NEMA 5-15P cord)
- Mirrored Ends Rear
- Sliding Doors
- Casters

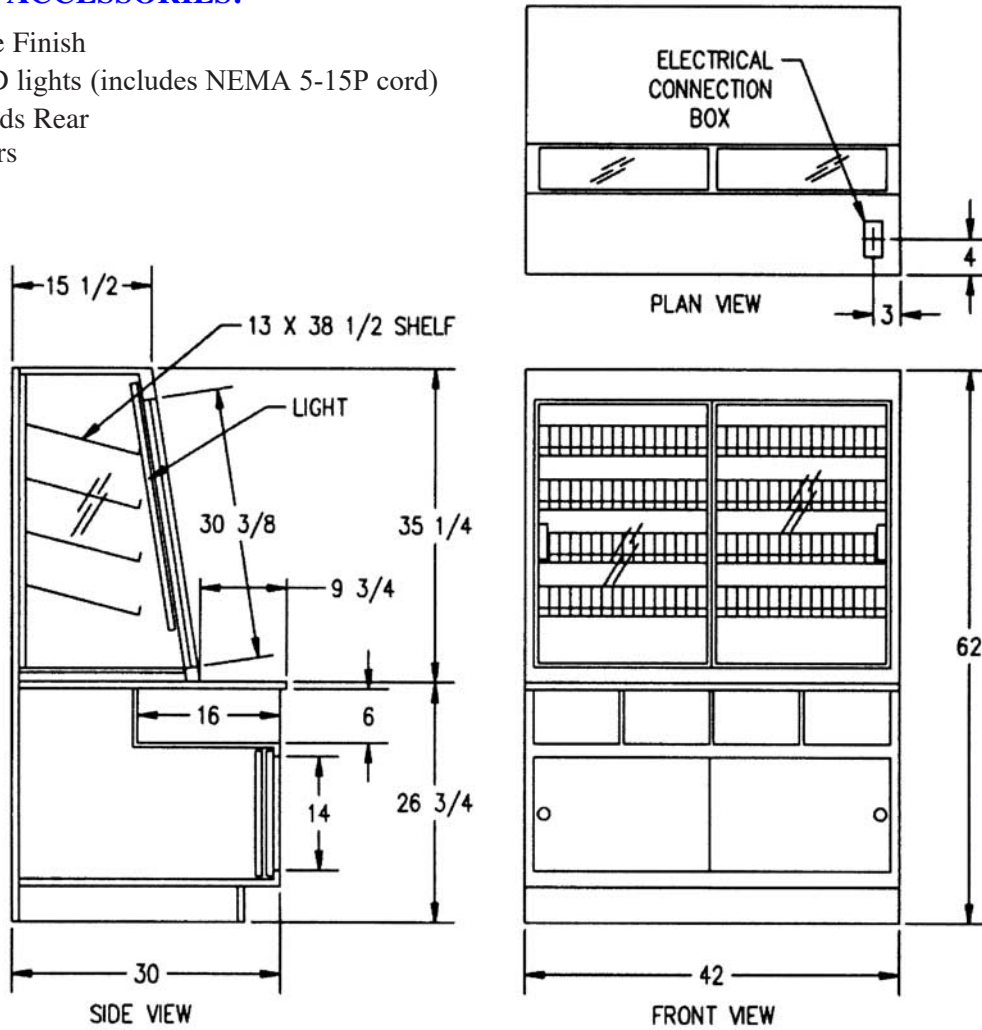

## SPECIFICATIONS:

Model	Dimensions			Shipping Weight (lbs)	Capacity (Bakery Pans)
	L	W	H		
WCD-42	42"	30"	62"	615	10 (12" x 18")

- If a GFCI circuit is required, a GFCI Breaker Must be used instead of GFCI receptacle.
- \*\* Electrical requirement for optional lights - 120/60/1 - 2 AMPS.
- Due to continuing engineering improvements, specifications are subject to change without notice.



**Look to Federal for Innovative Merchandising**



*The Signature of Quality*

**FEDERAL INDUSTRIES**  
A Standex Company

215 FEDERAL AVENUE, BELLEVILLE, WISCONSIN 53508-9201  
**PHONE: 800-356-4206**      **FAX: 608-424-3234**  
**EMAIL: geninfo@federalind.com**      **WEBSITE: www.federalind.com**

