



**John  
BOOS**  
Since 1887

ITEM #: \_\_\_\_\_ QTY: \_\_\_\_\_  
 MODEL #: \_\_\_\_\_  
 PROJECT NAME: \_\_\_\_\_

101518

3601 S. Banker St. Effingham, IL 62401 • P.O. BOX 609 • Ph: (888) 431-2667 • Fax: (800) 433-2667

## "C2H" CONDENSATE HOOD



### FEATURES:

- 18 GAUGE STAINLESS STEEL CONSTRUCTION
- FULL PERIMETER GUTTER
- STARTING EXHAUST DUCT COLLAR
- WELDED HANGING BRACKETS

### MATERIAL:

- HOOD: 18 GAUGE TYPE 300 STAINLESS STEEL
- BAFFLE: 18 GAUGE TYPE 300 STAINLESS STEEL

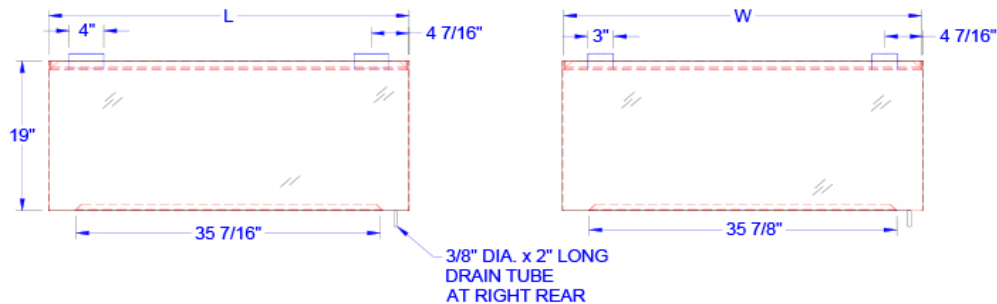
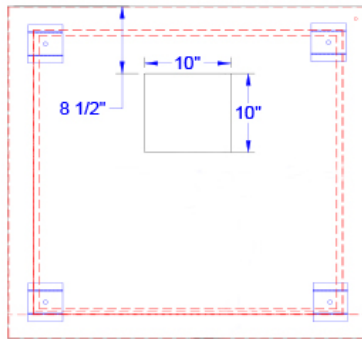

### CONDENSATE HOOD

MODEL #	LENGTH	WIDTH	HEIGHT	CFM	WT. (LBS)	QTY
C2H-36-2	36"	36"	19"	450	120	
C2H-42-2	42"	42"	19"	600	210	
C2H-60-2	60"	42"	19"	875	300	

WEIGHTS ARE SUBJECT TO ADDITIONAL PACKAGING

SOME UNITS SHIP UNASSEMBLED FOR REDUCED SHIPPING COST. ALL DIMENSIONS ARE TYPICAL. TOLERANCE +/- .500"

John Boos & Co. is constantly engaged in a program of improving products and therefore reserves the right to change specifications without prior notice.

