

ITEM #: _____ QTY: _____
 MODEL #: _____
 PROJECT NAME: _____

012318

3601 S. Banker St. Effingham, IL 62401 • P.O. BOX 609 • Ph: (888) 431-2667 • Fax: (800) 433-2667

"EUBBS" UNDERBAR BLENDER STATION

FEATURES:

- FABRICATED SINK BOWL
- STAINLESS STEEL LEGS AND BRACING WITH ADJUSTABLE BULLET FEET
- 4" ON-CENTER SPLASH MOUNT FAUCET HOLES

MATERIAL:

- TOP: 18GA 300 SERIES STAINLESS STEEL
- BRACING: STAINLESS STEEL
- LEGS: STAINLESS STEEL
- FEET: PLASTIC

CONSTRUCTION:

- TOP: STAINLESS STEEL TOPS ARE TIG WELDED, EXPOSED WELDS ARE POLISHED TO MATCH ADJACENT SURFACE.



UNDERBAR BLENDER STATION

MODEL #	QTY
EUBBS-1410	

UNDERBAR SPACE SAVER BLENDER STATION

MODEL #	QTY
EUBBS-0909	

DETAILED SPECIFICATIONS

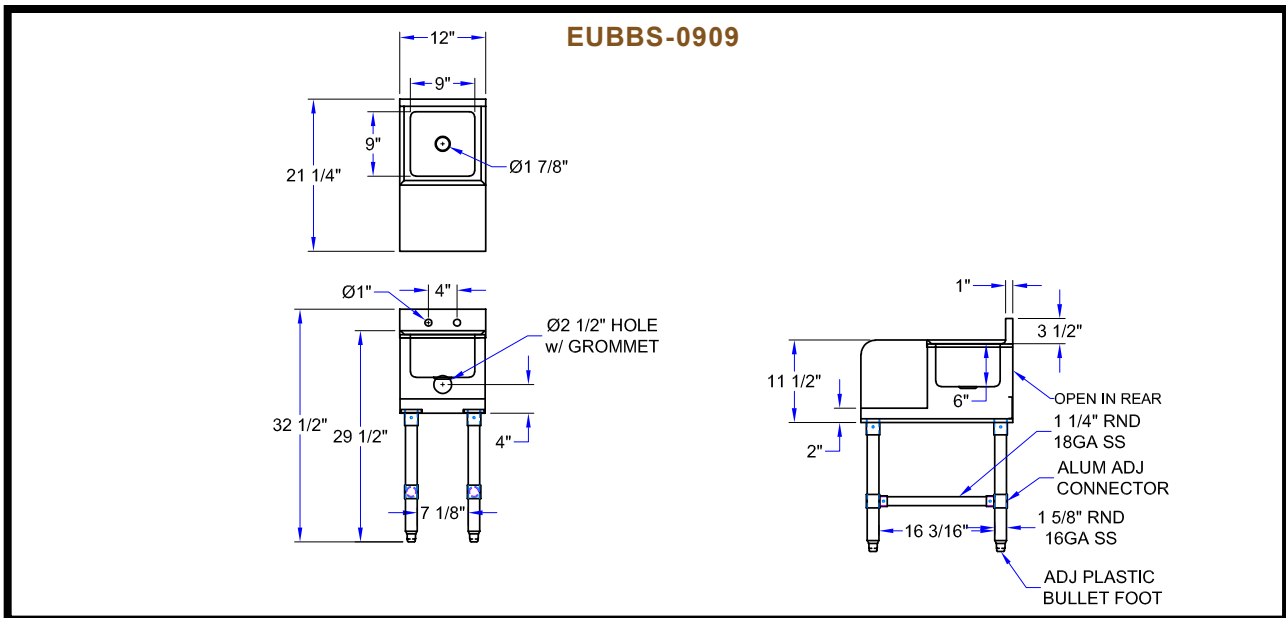
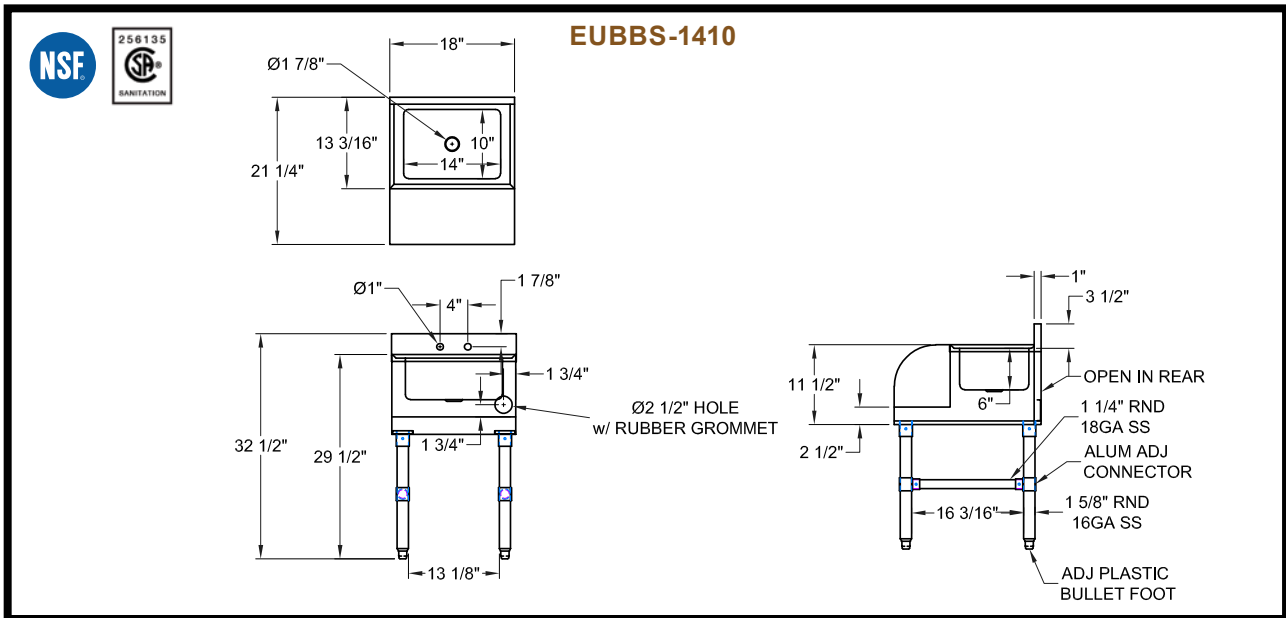

UNDERBAR BLENDER STATION

MODEL #	UNIT SIZE (L X W X H)	BOWL SIZE (L X W X H)	WT. (LBS)
EUBBS-1410	18" X 21-1/4" X 32-1/2"	14" X 10" X 6"	52

WEIGHTS ARE SUBJECT TO ADDITIONAL PACKAGING

UNDERBAR SPACE SAVER BLENDER STATION

MODEL #	UNIT SIZE (L X W X H)	BOWL SIZE (L X W X H)	WT. (LBS)
EUBBS-0909	12" X 21-1/4" X 32-1/2"	9" X 9" X 6"	30

WEIGHTS ARE SUBJECT TO ADDITIONAL PACKAGING

SOME UNITS SHIP UNASSEMBLED FOR REDUCED SHIPPING COST. ALL DIMENSIONS ARE TYPICAL. TOLERANCE +/- .500"
 John Boos & Co. is constantly engaged in a program of improving products and therefore reserves the right to change specifications without prior notice.



3601 S. Banker St. • Effingham, IL 62401 • PO BOX 609 • quotes@johnboos.com

121817

15



www.johnboos.com