



ITEM #: _____ QTY: _____
 MODEL #: _____
 PROJECT NAME: _____

121817

3601 S. Banker St. Effingham, IL 62401 • P.O. BOX 609 • Ph: (888) 431-2667 • Fax: (800) 433-2667

"EUBDS" UNDERBAR DUMP SINK



FEATURES:

- FABRICATED SINK BOWL: 10" X 14" X 6" DEEP
- STAINLESS STEEL LEGS AND BRACING WITH ADJUSTABLE BULLET FEET
- 4" ON-CENTER DECK MOUNT FAUCET HOLES

MATERIAL:

- TOP: 18GA 300 SERIES STAINLESS STEEL
- BRACING: STAINLESS STEEL
- LEGS: STAINLESS STEEL
- FEET: PLASTIC

CONSTRUCTION:

- TOP: STAINLESS STEEL TOPS ARE TIG WELDED, EXPOSED WELDS ARE POLISHED TO MATCH ADJACENT SURFACE.



EUBDS-1014

UNDERBAR DUMP SINK

MODEL #	QTY
EUBDS-1014	

OPTIONAL ACCESSORIES

MODEL #	QTY
STAINLESS STEEL LEGS	

DETAILED SPECIFICATIONS

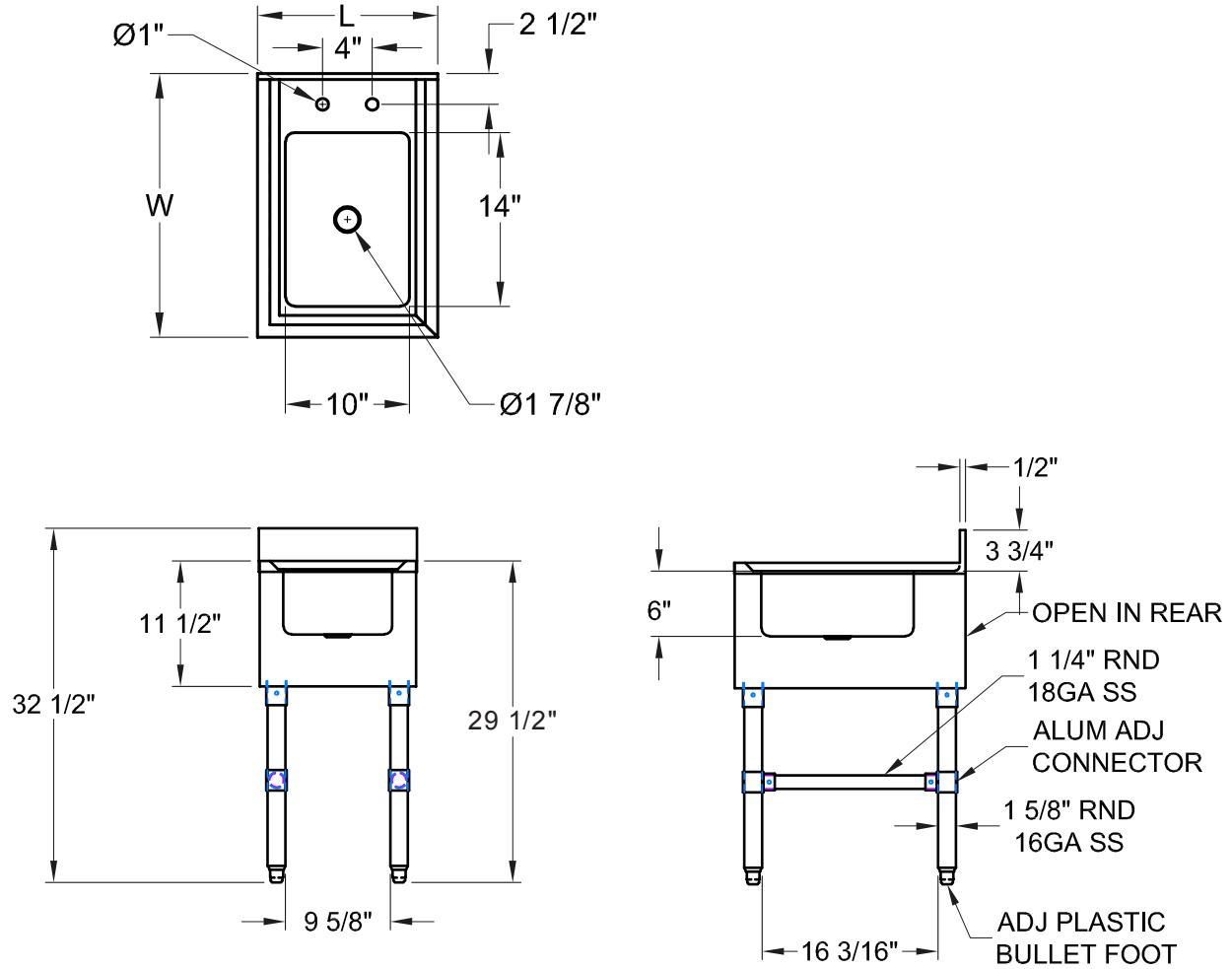

UNDERBAR DUMP SINK

MODEL #	LENGTH	WIDTH	HEIGHT	WT. (LBS)
EUBDS-1014	14"	21"	29-1/2"	38

WEIGHTS ARE SUBJECT TO ADDITIONAL PACKAGING

SOME UNITS SHIP UNASSEMBLED FOR REDUCED SHIPPING COST. ALL DIMENSIONS ARE TYPICAL. TOLERANCE +/- .500"
 John Boos & Co. is constantly engaged in a program of improving products and therefore reserves the right to change specifications without prior notice.



Boos
lock

AQ AutoQuotes

3601 S. Banker St. • Effingham, IL 62401 • PO BOX 609 • quotes@johnboos.com

www.johnboos.com

121817

17