

Durable Design

- Stainless steel interior & exterior
- Coated evaporator coil
- 3 height adjustable, heavy duty, PE coated wire shelves
- LED interior lighting
- Digital temperature display
- Door lock with keys
- Simple plug-in installation
- Oversized top mount compressor section
- Door swing is field reversible with kit # KB-TLHK

Energy Efficiency

- Self-closing door with stay open feature
- Seals tight with magnetic vinyl gasket
- Open door alert beeps when door is open for 3 minutes
- Foamed-in place high-density polyurethane insulated body, CFC-Free
- Large evaporator & condenser for quick cooling and greater efficiency

Superior Quality

- Designed for mobility, reliability & efficiency in commercial kitchens
- Certified with ETL guaranteeing quality standards
- 4" heavy duty swivel & locking front casters
- Easy grip handle
- Entirely self-contained system
- Automatic defrost system
- Digitally controlled temperature system
- Accommodates full-size bun sheet pans
- Easily adjustable shelf height
- Internal storage capacity is 20.5 cu. ft.
- NEMA 5-15 plug
- Compressor: Refrigerator - 1/3 HP / Freezer - 1/3 HP
- Holding temperature: Refrigerator 33°F to 39°F /

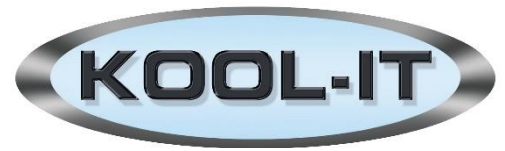

Single Door Series Refrigerator & Freezer Top Mount Compressor KTSR-1 / KTSF-1



Project Name:

Location:

Item: Qty:

Model:



5659 Royalmount Ave.
Montreal, QC, Canada H4P 2P9
Telephone: 514.737.9701 / Toll Free: 888.275.4538
Fax: 514.342.3854 / Toll Free: 877.453.8832
sales@mvpgroupcorp.com / mvpgroupcorp.com

12000 Biscayne Blvd., Suite # 108
Miami, FL, United States 33181
Telephone: 786.600.4687 / Toll Free: 844.218.8477
Fax: 786.661.4100

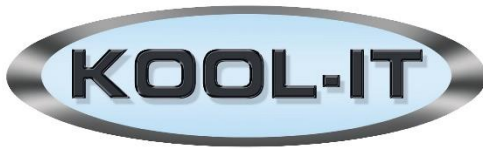

Technical Drawings KTSR-1 & KTSF-1

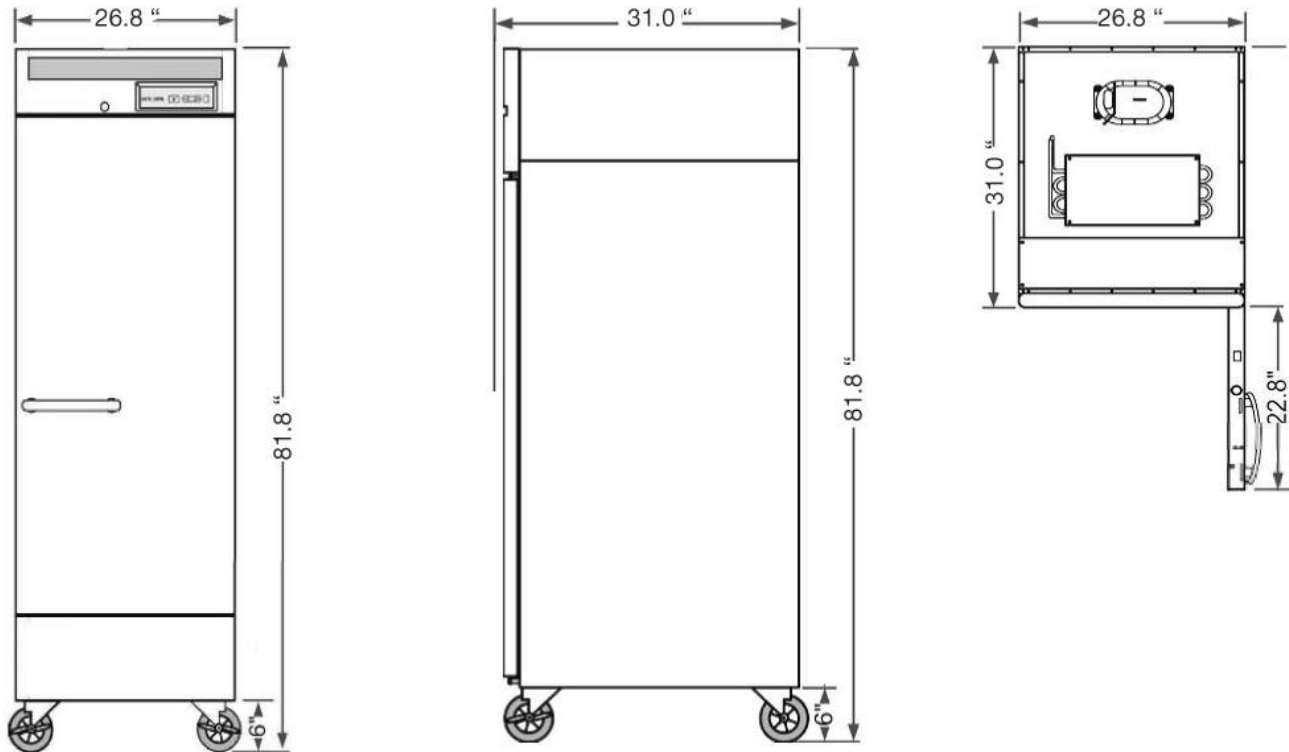

Model Number	Description	# of Doors	# of Shelves	Capacity (cubic ft)	External Dimensions w/handle (W x D x H in)	Internal Dimensions (W x D x H in)	Compressor Size	Voltage / Frequency	Amps	Working Temp	Refrigerant	Ship Weight (lbs)
KTSR-1	Top Mount Single Door Refrigerator	1	3	19.4	26.8 x 32.75 x 81.8	24.25 x 22.9 x 53.8	1/3	115V 60 HZ	6.4	33°F to 39 °F	R134a	315
KTSF-1	Top Mount Single Door Freezer	1	3	19.4	26.8 x 32.75 x 81.8	24.25 x 22.9 x 53.8	1/3	115V 60 HZ	8.0	5°F to -9°F	R404a	328

These units are designed for maximum performance in an air-conditioned area of 75°F ambient temperature and 55% relative humidity. There must be adequate ventilation at the top, sides & rear of the unit for proper operation.



Warranty: 36 months parts & labor.
Additional 24 months on compressor (parts only)

KOOL-IT is a registered trademark of MVP Group.
Specifications subject to change without notice.



5659 Royalmount Ave.
Montreal, QC, Canada H4P 2P9
Telephone: 514.737.9701 / Toll Free: 888.275.4538
Fax: 514.342.3854 / Toll Free: 877.453.8832
sales@mvpgroupcorp.com / mvpgroupcorp.com

12000 Biscayne Blvd., Suite # 108
Miami, FL, United States 33181
Telephone: 786.600.4687 / Toll Free: 844.218.8477
Fax: 786.661.4100