



Project \_\_\_\_\_

Item No. \_\_\_\_\_

Quantity \_\_\_\_\_

## COMBO SERIES

### Gas Deck Pizza Ovens



#### Model(s) Available

- MBC 448** - MB 42 with flat top, 8" high door, and 36" x 42" cooking surface stacked over SD 448 with 7" high door and 36" x 48" cooking surface
- MBC 1048** - MB 42 with flat top, 8" high door, and 36" x 42" cooking surface over SD 1048 with 10" high door and 36" x 48" cooking
- MBC 660** - MB 60 with flat top and 8" high door stacked over SD 660 with 7" high door and 36" x 60" cooking surface per section
- MBC 1060** - MB 60 with flat top and 8" high door stacked over SD 1060 with 10" high door and 36" x 60" cooking surface per section



## Construction

#### MB 42 & MB 60

- Light counter weight double panelled door creates an air shield, reducing heat loss and keeping the oven workspace cool
- 2" thick cooking surface
- Stainless steel sides and top
- Ultra high temperature fiberglass insulation allows for 0" clearance on both sides
- Arched refractory brick-lined ceiling for an even, efficient oven temperature

#### SD 448, SD 660, SD 1048 & SD 1060

- A spring balanced door provides easy access to the baking chamber
- Exclusive Marsal burner for superior bake
- 2" thick cooking surface
- 18 gauge stainless steel top, front, sides and doors
- Heavy duty legs

## Operation

- Thermostatically controlled from 300°F to 650°F
- Bright interior halogen light on MB section

## Standard Features

- Stainless steel front
- Flat top oven, optional round dome top available
- Warranty: 1 year labor, 18 months parts

## Options & Accessories

(AT ADDITIONAL CHARGE)

- Round dome top
- Aluminized front skirting to allow ovens to be decorated with tile, brick, etc.
- Set of 4 casters (2 locking, 2 non-locking)

SHORT FORM SPECIFICATIONS: Provide Marsal MBC 448, MBC 1048, MBC 660 or MBC 1060 oven(s). MB section shall have an arched refractory brick-lined ceiling for even temperature. Ultra high temperature fiberglass insulation allows for 0" clearance on both sides. Light counter weight double panelled door creates an air shield, reducing heat loss and keeping the workspace cool. 2" thick cooking surface. SD section shall have a spring balanced door provides easy access to the baking chamber with a 2" thick cooking surface. Oven top, sides and doors are build of 18 gauge stainless steel. The Heavy duty legs are welded to the oven's base. Both sections are thermostatically controlled from 300°F to 650°F. Provide with eighteen month oven parts and one year labor warranty. Provide with options and accessories as indicated.



DIMENSIONS ARE IN INCHES [MM]

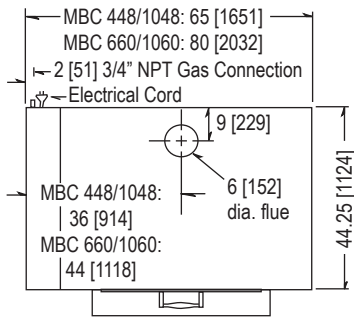

TOP VIEW  
All Models

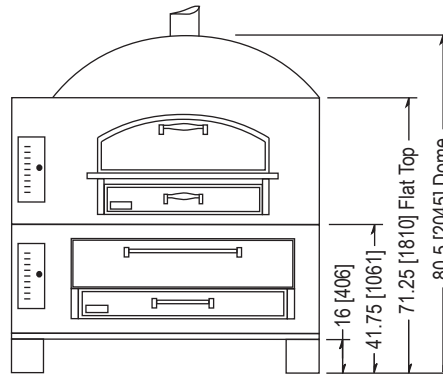

FRONT VIEW - MBC 448 / MBC 660

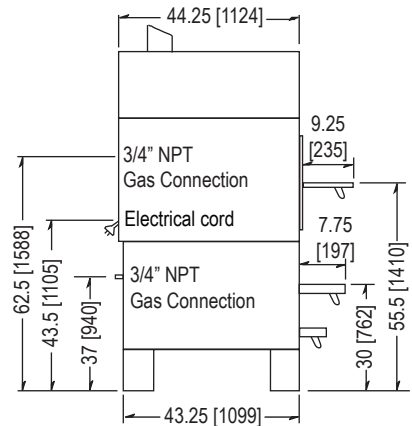

SIDE VIEW - MBC 448 / MBC 660

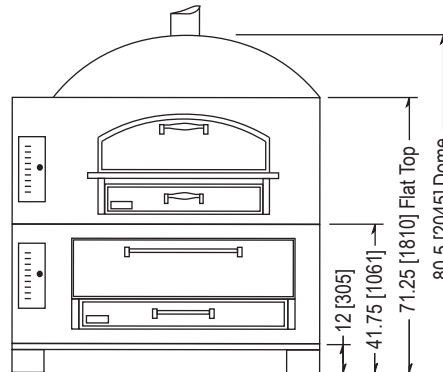

FRONT VIEW - MBC 1048 / MBC 1060

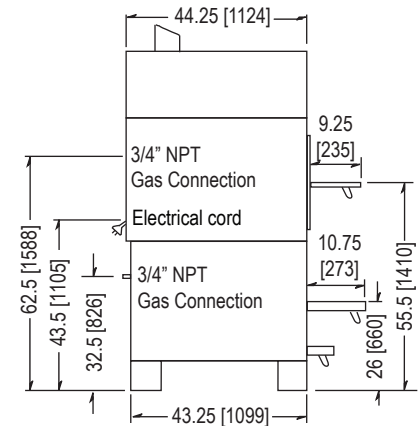

SIDE VIEW - MBC 1048 / MBC 1060

## Specifications

	MBC 448	MBC 1048	MBC 660	MBC 1060
<b>Height:</b> Dome Flat	80.5" [2045] 71.25" [1810]		80.5" [2045] 71.25" [1810]	
<b>Depth &amp; Length</b>	44.25" x 65" [1124 x 1651]		44.25" x 80" [1124 x 2032]	
<b>Cooking Surface:</b> Top Bottom	36" x 42" [914 x 1067] 36" x 48" [914 x 1219]		36" x 60" [914 x 1524] 36" x 60" [914 x 1524]	
<b>Clearance</b>	3" space must be left at the rear to allow adequate clearance for air openings			
<b>BTUs</b>	LP: (2) 90,000 NAT: (2) 95,000		LP: (2) 120,000 NAT: (2) 130,000	
<b>Electrical</b>	(1) 120 VAC		(1) 120 VAC	
<b>Shipping Weight</b>	2,300 lbs (1043 kg)	2,375 lbs (1077 kg)	2,917 lbs (1323 kg)	3,100 lbs (1406 kg)
<b>Capacity</b>	(8) 18" pies		(12) 18" pies	

All designs and specifications presented in this document are subject to change without notice due to constant innovation.