



The Legacy Companies
 3355 Enterprise Avenue, Suite 160, Fort Lauderdale, FL 33331
 Sales: (954) 202-7419 • Sales@TheLegacyCompanies.com
 Tech Service: (877) 368-2797 • Service@MaxxHelp.com

Project Name: _____
 Location: _____
 Item #: _____ Qty: _____
 Model: _____

www.MaxximumFoodService.com

ICE MAKER STORAGE BINS

Model: MIB310N MIB470N MIB580N MIB580



MIB310N & MIB470N shown with Maxx Ice modular ice maker heads (sold separately)

These ice maker storage bins are designed to fit perfectly with the Maxx Ice series of 22" and 30" modular ice makers. Gravity Drain is required.

Features and Construction

- Exterior Material: Corrosion resistant stainless steel and plastic (MIB580 comes with stainless steel lid, MIB310N/470N/580N come with black plastic lids)
- LED illuminated interior when storage bin access door is open (powered by ice maker head)
- Scoop holder keeps scoop above the ice line for easy access and better sanitation
- 6" Leveling Legs (4)
- 3/4" Drain Hookup for efficient discharge of any ice melt condensate

Compatible Maxx Ice Modular Ice Maker Models*:

MIB310N: 2 Models - MIM360N/NH

MIB470N/580N/580:

8 Models - MIM370N/NH, MIM500N/NH, MIM650N/NH, MIM1000N/NH

*Bins will accommodate any similarly sized ice maker from any manufacturer

	MIB310N Bin	MIB470N Bin	MIB580N/580 Bin
In: External Dimensions W x D x H	22 x 34 x 41.4	30 x 34 x 41.4	30 x 34 x 50
mm: External Dimensions W x D x H	564 x 864 x 1052	763 x 864 x 1052	763 x 864 x 1270
Ice Storage Capacity	310 lbs (141 kg)	470 lbs (213 kg)	580 lbs (263 kg)
AHRI Capacity	246 lbs (112 kg)	376 lbs (171 kg)	464 lbs (210 kg)
Insulation	2" Polyurethane Foam	2" Polyurethane Foam	2" Polyurethane Foam
Shipping Weight	99.5 lbs (45 kg)	117 lbs (53 kg)	164 lbs (75 kg)
Utility Connection	3/4" Drain Line	3/4" Drain Line	3/4" Drain Line

MIB310N Bin Dimensions

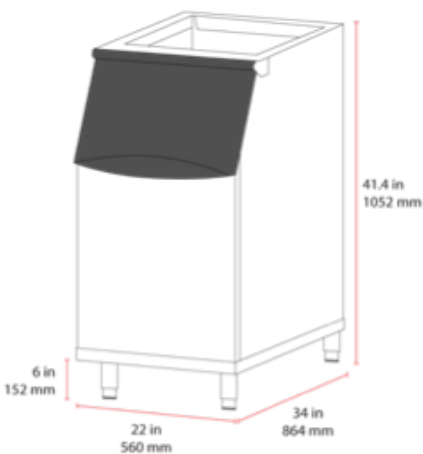

MIB470N Bin Dimensions

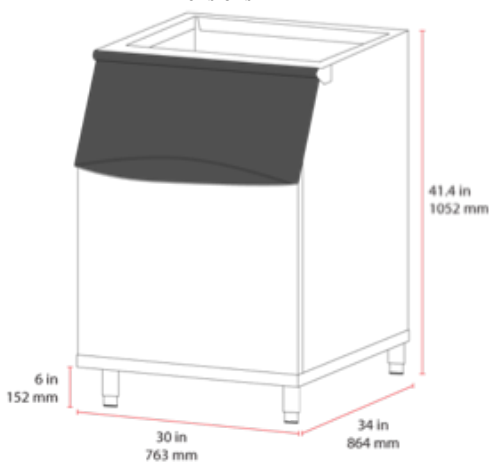

MIB580N/580 Bin Dimensions

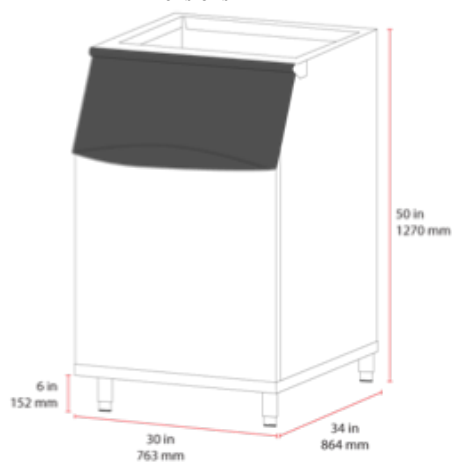

NSF 2

Made with 2" thick environmentally friendly foam insulation to minimize ice melt and deliver a better environment for ice storage.

Maxx Ice WARRANTY (USA / CANADA)

Three (3) years parts

Three (3) years on-site labor

Five (5) years compressor (part only)

Administered by The Legacy Companies, 877.368.2797

Due to periodic changes in designs, methods, procedures, policies and regulations, the specifications contained in this sheet are subject to change without notice. While we exercise good faith efforts to provide information that is accurate, we are not responsible for errors or omissions in information provided or conclusions reached as a result of using the specifications. By using the information provided, the user assumes all risks in connection with such use.

The built in performance enhancing functions ensure that given proper attention and preventative maintenance, each Maxx Product will deliver years of trouble free, reliable, low maintenance, efficient operation.