



NOR-LAKE, INCORPORATED
727 Second Street
Hudson, Wisconsin 54016

800-955-5253
715-386-2323
866-961-5253 Parts
800-388-5253 Service
715-386-6149 FAX
www.norlake.com

TOPPING - DIPPING CABINETS



PROJECT:

ITEM NUMBER:

MODEL NUMBER:

SPECIFICATIONS FOR: ZF124, ZF174

- **Exterior Finish:** 24 gauge white polyester enamel painted steel with stainless steel top
- **Interior Finish:** Galvanized steel inner liner
- **Insulation:** 2-1/4" foamed-in-place "zero ODP" urethane insulation
- **Hardware:** Stainless steel lids hinged with handles. Equipped with levelling legs to correct for un-level flooring situations. Floor drain with standard hose fitting.
- **Electrical:** 115 volt, 60 HZ, 1 phase with cord and plug
- **Refrigeration:** Self-contained, slide out, factory tested refrigeration system. Forced draft hermetic condensing unit with wire and tube condenser for low maintenance. Temperature range 0°F to -10°F (-18°C to -23°C)
- **Approvals:** UL & C-UL Sanitation **, NSF listed

STANDARD FEATURES

- 20 gauge seamless stainless steel top
- Anti-condensate heaters under stainless top cap
- Floor drain
- Leveling legs
- UL, C-UL Sanitation **, NSF listed
- Warranties: 2 year parts and labor, 5 year compressor

OPTIONAL FEATURES *

- Casters
- Dipper well
- Legs
- Lid locking kit (less lock)
- Pumps and jar assemblies
- Stainless steel exterior (SVS)

* Most options are available two weeks from receipt of order. Please contact us for specific questions.

**C-UL is Underwriters Laboratories Safety Certification Mark which indicates that UL has tested the equipment to applicable CSA Standards.

**UL Sanitation is Underwriters Laboratories Sanitation Mark which indicates that UL has tested the equipment to applicable NSF Standards.

TOPPING - DIPPING CABINETS

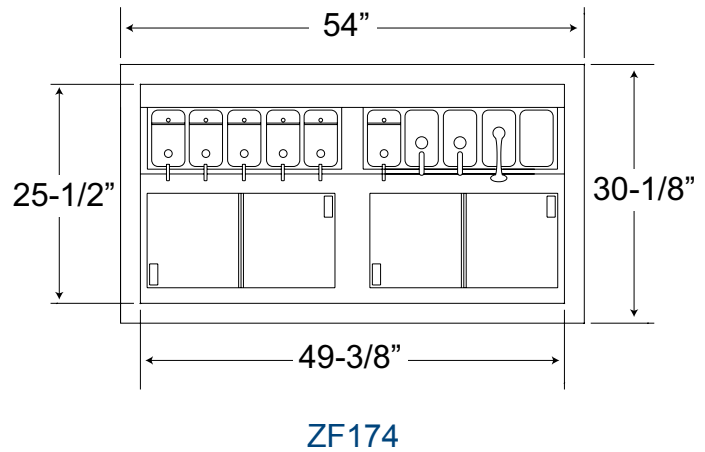
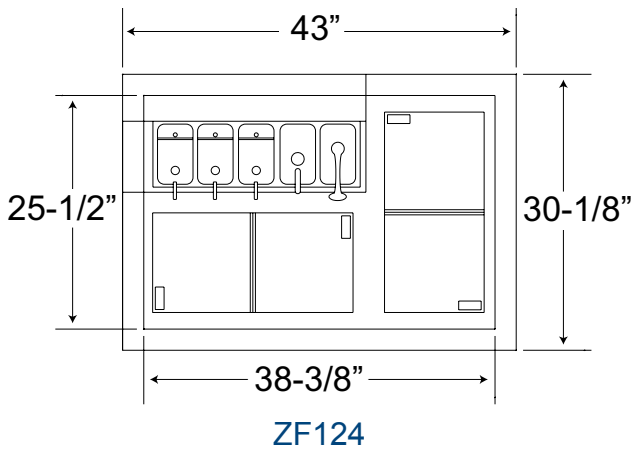

SPECIFICATIONS

Models	ZF124	ZF174
<i>Crated Weight (lbs) (kg)</i>	300 (136)	340 (153)
<i>Crated Height (in) (cm)</i>	46 (115)	46 (115)
<i>Crated Width (in) (cm)</i>	57 (143)	68-1/2 (171)
<i>Crated Depth (in) (cm)</i>	40 (100)	40 (100)
<i>Interior Height (in) (cm)</i>	27 (68)	27 (68)
<i>Interior Display Width (in) (cm)</i>	38-3/8 (96)	49-3/8 (123)
<i>Interior Storage Width (in) (cm)</i>	25-5/16 (63)	36-3/8 (91)
<i>Interior Depth (in) (cm)</i>	25-1/2 (64)	25-1/2 (64)
<i>Overall Height (in) (cm)</i>	38-1/4 (96)	38-1/4 (96)
<i>Overall Width (in) (cm)</i>	43 (108)	54 (135)
<i>Overall Depth (in) (cm)</i>	30-1/8 (75)	30-1/8 (75)
<i>Gross Cubage (CuFt) (L)</i>	12.5 (354)	16.8 (475)
<i>Can Capacity Display *</i>	5	6
<i>Can Capacity Storage *</i>	7	11
<i>Condensing Unit Size</i>	1/4 HP	1/3 HP
<i>Refrigerant</i>	R-134a	R-134a
<i>Electrical Characteristics</i>	115/60/1	115/60/1
<i>Cord and Plug Furnished</i>	Yes	Yes
<i>NEMA Plug Configuration</i>	5-15P	5-15P
<i>Total Amp Draw</i>	5.7	7.3

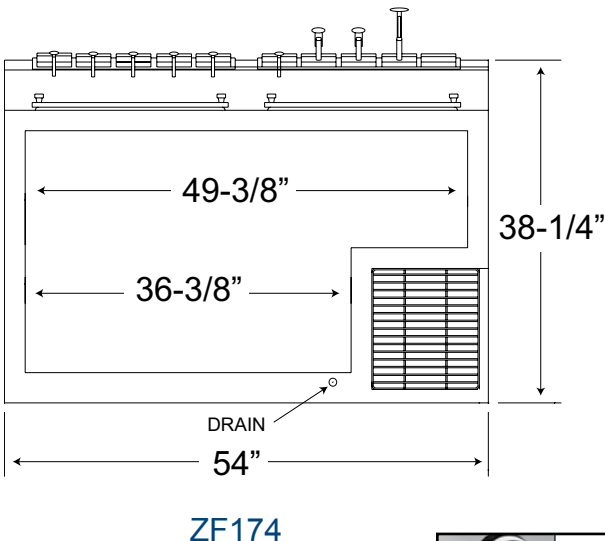
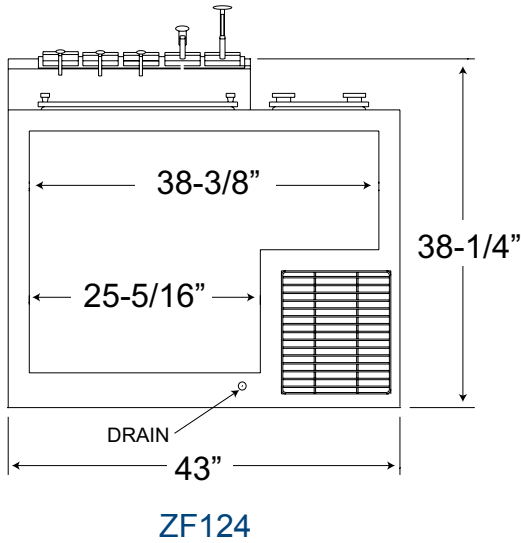

Specifications subject to change without notice.

** Can capacities in 9-1/2" diameter, 3 gallon cans.*



Revision Date: 12/17
 © 2017 NOR-LAKE, INC.
 Printed in the U.S.A.
 Part Number: 144104