

**CAN BE CUSTOMIZED  
WITH YOUR LOGO.**



R3-BCI

The Piper Beverage Cooler is good for back bar or self service ice units for beverages. These units are designed to serve a variety of refrigerated food products and are ideal as a salad bar merchandiser. The versatile modular design allows you to do stand alone kiosks, cafeteria or a buffet unit. Units are compatible and will interlock with other Reflections units.

**STANDARD FEATURES**

- ◆ Seamless, molded FRP body with smooth exterior and rounded corners
- ◆ 14-gauge stainless steel top with fully welded square turndowns on all sides
- ◆ Enclosed base
- ◆ 20-gauge stainless steel fully welded 5" deep cold pan
- ◆ Welded, watertight well
- ◆ Cold pan has a 3/4" FPT drain ball valve located below the unit
- ◆ 4" diameter swivel plate casters with brakes
- ◆ Interlocking mechanism is provided to interlock with other Reflections units

JOB \_\_\_\_\_ ITEM # \_\_\_\_\_ QTY # \_\_\_\_\_

**MODEL NUMBER**

- R2-BCI
- R3-BCI
- R4-BCI

**DIMENSIONS**

- ◆ R2-BCI - 36"H x 30"D x 36"L
- ◆ R3-BCI - 36"H x 30"D x 50"L
- ◆ R4-BCI - 36"H x 30"D x 60"L

**STANDARD COLORS**

- Wine Red (RAL 3005)
- Signal Red (RAL 3001)
- Yellow (RAL 1021)
- Light Blue (RAL 5012)
- Gentiane Blue (RAL 5010)
- Water Blue (RAL 5021)
- Moss Green (RAL 6005)
- Squirrel Gray (RAL 7000)
- Black
- White
- ◆ Custom colors available
- ◆ Optional Graphics Packages available

**COMMON OPTIONS**

- ◆ Unit can be customized with your logo
- ◆ Tray slides
- ◆ Protector guards
- ◆ See reverse side for additional options

**WARRANTY**

- ◆ One year parts and labor. Warranty is detailed on
- ◆ inside front cover of the price list.

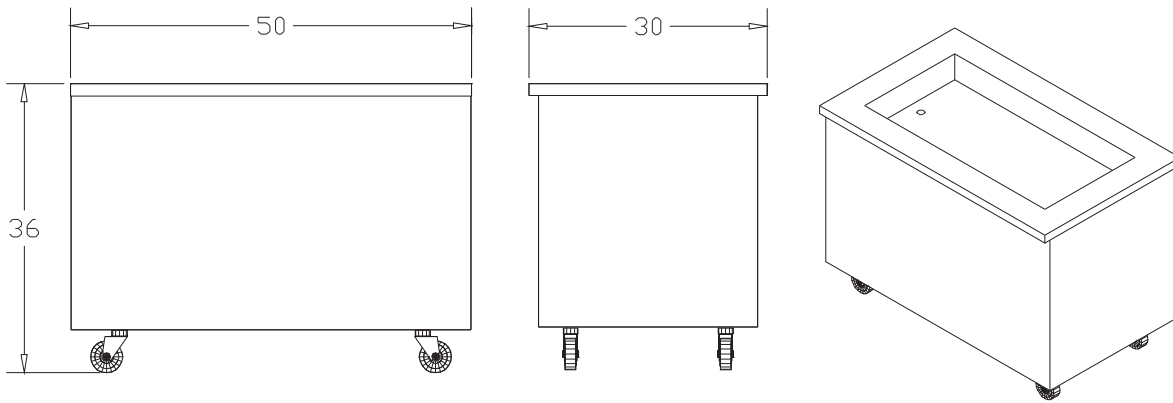

Model#	12x20 Pan Capacity	(A) Length	Width	(B) Height	Ship Wt. (lbs)	Capacity*
R2-BCI	2	36"	30"	36"	350	80
R3-BCI	3	50"	30"	36"	485	120
R4-BCI	4	60"	30"	36"	500	160

\*Based on 12oz. bottles. Capacities will vary depending on product and ice usage.

### DIMENSION ADDITIONS FOR OPTIONS

- ◆ Add 23-3/4" to height for buffet protector guard
- ◆ Add 14" to height for cafeteria protector guard
- ◆ Add 22-3/4" to height for 2-tier display stand
- ◆ Add 8" to width for cutting board
- ◆ Add 12-3/4" to width for solid ribbed tray slide
- ◆ Add 12-1/2" to width for 3-bar tray slide

Note: Line-up drawing required when ordering false front, cashier stand or interconnected units.

Part #	Description
<input type="checkbox"/> RSCB	8" stainless steel cutting board
<input type="checkbox"/> RMCB	8" maple cutting board
<input type="checkbox"/> RSRTS	Solid 3-ribbed tray slide, 16-gauge stainless steel
<input type="checkbox"/> RSFTS	Solid flat tray slide, 16-gauge stainless steel
<input type="checkbox"/> R3BTS	3-bar tray slide
<input type="checkbox"/> RSES	End shelf - drop type
<input type="checkbox"/> RBHL	Heat lamps, bullet-type (buffet only)
<input type="checkbox"/> RCPG	Cafeteria style protector guard
<input type="checkbox"/> RCPGC	Classic tubular glass cafeteria guard
<input type="checkbox"/> RCPGL	Cafeteria style protector guard with incandescent lights
<input type="checkbox"/> RCPGFL	Cafeteria style protector guard with fluorescent lights
<input type="checkbox"/> RCPGHL	Cafeteria style protector guard with heat and light strips
<input type="checkbox"/> RCPGH	Cafeteria style protector guard with heat strips
<input type="checkbox"/> RCDD	Two tier cafeteria protector guard
<input type="checkbox"/> RCDDC	Classic two tier tubular glass cafeteria guard
<input type="checkbox"/> RCDDL	Two tier cafeteria protector guard with fluorescent lights
<input type="checkbox"/> RCEG	Cafeteria end guards (pr)
<input type="checkbox"/> ROHS	Overhead shelf
<input type="checkbox"/> RSCPGC	Cafeteria single tubular vertical glass guard
<input type="checkbox"/> RBPG	Buffet style protector guard
<input type="checkbox"/> RBPGC	Classic tubular glass buffet guard

Part #	Description
<input type="checkbox"/> RBPGIL	Buffet style protector guard with incandescent lights
<input type="checkbox"/> RBPGFL	Buffet style protector guard with fluorescent lights
<input type="checkbox"/> RBPGH	Buffet style protector guard with heat strips
<input type="checkbox"/> RBPG1	Single sided buffet style protector guard
<input type="checkbox"/> RBPG1C	Classic single sided tubular glass buffet guard
<input type="checkbox"/> RBPG1IL	Single sided buffet style protector guard with incandescent lights
<input type="checkbox"/> RBPG1FL	Single sided buffet style protector guard with fluorescent lights
<input type="checkbox"/> RBDD	Two tier buffet protector guard
<input type="checkbox"/> RBDDL	Two tier buffet protector guard with fluorescent lights
<input type="checkbox"/> RBEG	Buffet end guards (pr)
<input type="checkbox"/> ROU	Open under storage with shelf
<input type="checkbox"/> RHD	Under storage hinged doors
<input type="checkbox"/> RHU	Heated storage base with doors and pan slides (convertible racks hold 10 - 2" deep 12" x 20" pans or 10 - 18" x 26" bun pans)
<input type="checkbox"/> RBL	Stainless steel 6" adjustable bullet feet
<input type="checkbox"/> RDOUT	Duplex outlet (120V, 15 AMP)
<input type="checkbox"/> RMRCE	Extended Compressor Warranty
<input type="checkbox"/> RRB	Perforated false bottom
<input type="checkbox"/> RRU	Refrigerated storage base with door and pan slides: holds 8-2" deep 12"x20" pans

## B-13 SPEC

**PIPER PRODUCTS**  
**BUILT TO LAST**  
[www.piperonline.net](http://www.piperonline.net)

300 S. 84th Avenue  
 Wausau, WI 54401  
 Phone: 800-544-3057  
 Fax: 715-842-3125

**LIMITED WARRANTY:** PIPER PRODUCTS warrants to the original purchaser parts and labor for a period of twelve (12) months from the date of purchase. See manufacturer's complete warranty for details.

It is our policy to build equipment which is design certified by companies that have been accredited at the Federal Level by the Occupational Safety and Health Agency (OSHA) and ANSI as a National Recognized Testing Laboratory. These companies include CSA International, Underwriters Laboratories, and the National Sanitation Foundation. However, a continuing program of product improvement makes it necessary to submit new models to the agencies as they are developed. Consequently, all models may not bear the appropriate labels at all times.

We reserve the right to change specifications and product design without notice. Such revisions do not entitle buyer to corresponding changes, improvements, additions or replacements for previously purchased equipment. Information is not for design purposes.