



Specification

Mon Sep 09 09:39:31 CEST 2019

CombiMaster® Plus CMP 61 G (6 x 12 x 20 inch/6 x 13 x 18 inch)



Capacity

- Six (6) Half-size sheet pans (13"x18") or Six (6) Steam table pans (12"x20"x2.5") GN1/1
- Removable, swivelling hinging rack
- Vertical distance between rails 2 5/8" (68 mm)

Standard Features

- Gas heated table device for cooking of meat, poultry, fish, side dishes, vegetables, egg dishes, desserts, bakery products and for automatic rethermalization
- Combi-steamer according to DIN 18866, DIN 10535 for selective use of steam and hot air, separately, sequentially, or combined
- 2-Year parts and labor warranty
- 5-Year steam generator warranty
- No-charge 4-hour RATIONAL certified chef assistance program
- Probe for core temperature measurement
- ClimaPlus® – humidity measurement, 5 stage setting and regulation
- Combi-steamer mode °F/(°C): steam: 85 to 265/(30 to 130), hot air: 85 to 575/(30 to 300), combination: 85 to 575/(30 to 300)

- Individual programming of at least 100 cooking programs with up to 6 steps transferable via USB
- High-performance fresh steam generator, pressureless
- 5 programmable fan speeds
- Integral, maintenance-free grease extraction system with no additional grease filter
- Single water connection as shipped, can be split connection for treated and untreated water
- Turbo fan cool down function
- Dynamic air mixing
- Automatic adaptation to the installation location (elevation)
- Unit door with rear-ventilated double-glass panel and hinged inner panel
- Height adjustable feet +/- 3/8" (10 mm)
- 304 (DIN 1.4301) stainless steel material inside and out
- Seamless interior and with rounded corners
- Temperature units can be set in °F/(°C)
- Digital temperature display
- Digital timer, 0-24 hours with permanent setting
- USB Interface
- Demand-related energy supply

Operation

- Mode selector for cooking modes, separate controls for temperature, core temperature and time settings
- LED illuminated display, visible from a distance
- Clear control panel

Safety features

- Detergent and rinse tabs (solid detergents) for optimum working safety
- VDE approved for unsupervised operation
- HACCP data output and software update via integral USB port
- Safety temperature limiter for steam generator and hot-air heating
- Maximum rack height 5 1/4 ft./1.60 m when original stand is used
- Integral fan impeller brake
- Door handle with right/left and slam function
- Splash an hose-proof to IPX5

Cleaning & care

- 3 automatic cleaning programs
- Service Diagnostic system (SDS) with automatic service notices displayed
- Menu-guided user descaling program
- Hand shower with automatic retracting system

Approval/Labels





Specification

Mon Sep 09 09:39:31 CEST 2019

CombiMaster® Plus CMP 61 G (6 x 12 x 20 inch/6 x 13 x 18 inch)

Combi-Steamer mode



Steam between 85-265 °F (30-130 °C)



Hot-air from 85-575 °F (30-300 °C)



Combination of steam and hot-air 85-575 °F (30-300° C)

ClimaPlus



Climate management - humidity measurement, 5-stage setting and regulation

Technical Specification

Dimensions	Width	Depth	Height
Exterior	33 3/8" (847 mm)	30 1/2" (776 mm)	30 3/4" (782 mm)
Incl. Vent/Handle	-	33" (838 mm)	32 3/4" (832 mm)
Shipping	37 3/8" (950 mm)	36 1/4" (920 mm)	39 3/8" (1,000 mm)

Weight	
Max Per Shelf	33 lbs
Max Load Size	66 lbs
Net	266 lbs
Shipping	299 lbs

Size	Electric. 60 hz	Breaker	Cable connection	Running Amps
61	120V 1 PH	15 A	5-15P	3.33 amps
61	208V 1 PH	15 A	6-15P	1.92 amps
61	240V 1 PH	15 A	6-15P	1.67 amps

Gas units are supplied with 8 ft. 14-3 AWG cord and plug. 120V 1Ph L1, N, G or 208/240V 1 Ph L1, L2, G (208V is field retrofittable to 240V). Dedicated 2 pole circuit breaker required. Due to GFCI having a 4-6mA tolerance, 208/240V is recommended. Do not use fuses. Special voltages available upon request.

Thermal load and airflow requirements

Latent	595 W
Sensible	714 W
Unit free standing	13314 ft³/hr
One side against a wall	8405 ft³/hr
Noise values	70 dBA

Rated thermal load

	Natural gas	Liquid gas LPG
Total:	49,000 BTU	48,200 BTU
Steam:	45,500 BTU	44,500 BTU
Hot air:	49,000 BTU	48,200 BTU
Required gas pressure:	6.5" – 10" w.c.	10" – 13" w.c.

Connected load electric: 0.4 kW
Gas supply/connection: 3/4" NPT with 3/4" gas shut off

Water Requirements

Connection	3/4"
Supply	Minimum 1/2" ID Drinking Quality Cold
Pressure	21-87 psi (1.5-6 bar)
Average Water Consumption	0.8 gal/h
Min/Max Flow Rate	3 gpm/5.27 gpm
Water Drain	2" OD (50 mm) hub

Connect only to 2" (XS = 1 1/2") high-temperature resistant pipe. Water discharge temperature can be field adjusted to meet section 701.7 of the International Plumbing Code. Contact RATIONAL for back flow recommendation.

Water Quality

Untreated water can be 0 to 24.5 gr/gal (0 to 420ppm) hardness. We do not recommend treated water hardness < 5 gr/gal (86ppm) because the water could be corrosive. Sodium ion exchangers are not recommended; H+ Ion exchange systems are recommended. Water that does not meet the following minimum standards will require the proper conditioning.

Contaminant	Water Requirements	If > than recommended
Sand/Particles	< 15 µm	Particle filter
Chlorine (Cl ₂)	< 0.12 gr/gal (0.2 ppm)	Active carbon filter
Chloride (Cl ₋)	< 4.68 gr/gal (80 ppm)	RO or deionization

Clearance Requirements

To facilitate servicing, we recommend leaving a 18"-20" (450-500 mm) gap on the left-hand side of the unit. If there is not 18"-20" (450-500 mm) left side clearance available, provisions for moving the unit or appliance to the left for service access must be made. These include, but are not limited to, having quick connections (water, gas, etc.) and lengthened electrical connections with flexible cords. If there are no external heat sources acting on the unit, there should be a minimum gap of 2" (50 mm) to the left, right, and back of unit. If a high temperature heat source is on the left side of the unit, the left-hand gap must be a minimum of 14" (350 mm). This gap may be reduced to 2" (50 mm) by using a heat shield (see options). Recommended clearance from unobstructed rear exhaust pipes and any surface collecting grease or flammable material; 16" (400 mm) gas, 10" (254 mm) electric. It is recommended to have a hood overhang of 6" (150 mm) to 18" (450 mm) at the front of the unit and 6" (150 mm) on the side if installed at the end of the cooking line. Please refer to the Installation Manual for further technical data and for instructions on installation and setup. Installations must comply with all local electrical, plumbing, and ventilation codes. test test test

RATIONAL USA Inc.

1701 Golf Road, Suite C-120, Commerceium
Rolling Meadows, IL 60008
Toll Free: 888-320-7274, Fax.: 847-755-9583

Visit us on the internet: www.rationalusa.com

We reserve the right to make technical improvements



Specification

Mon Sep 09 09:39:31 CEST 2019

CombiMaster® Plus CMP 61 G (6 x 12 x 20 inch/6 x 13 x 18 inch)

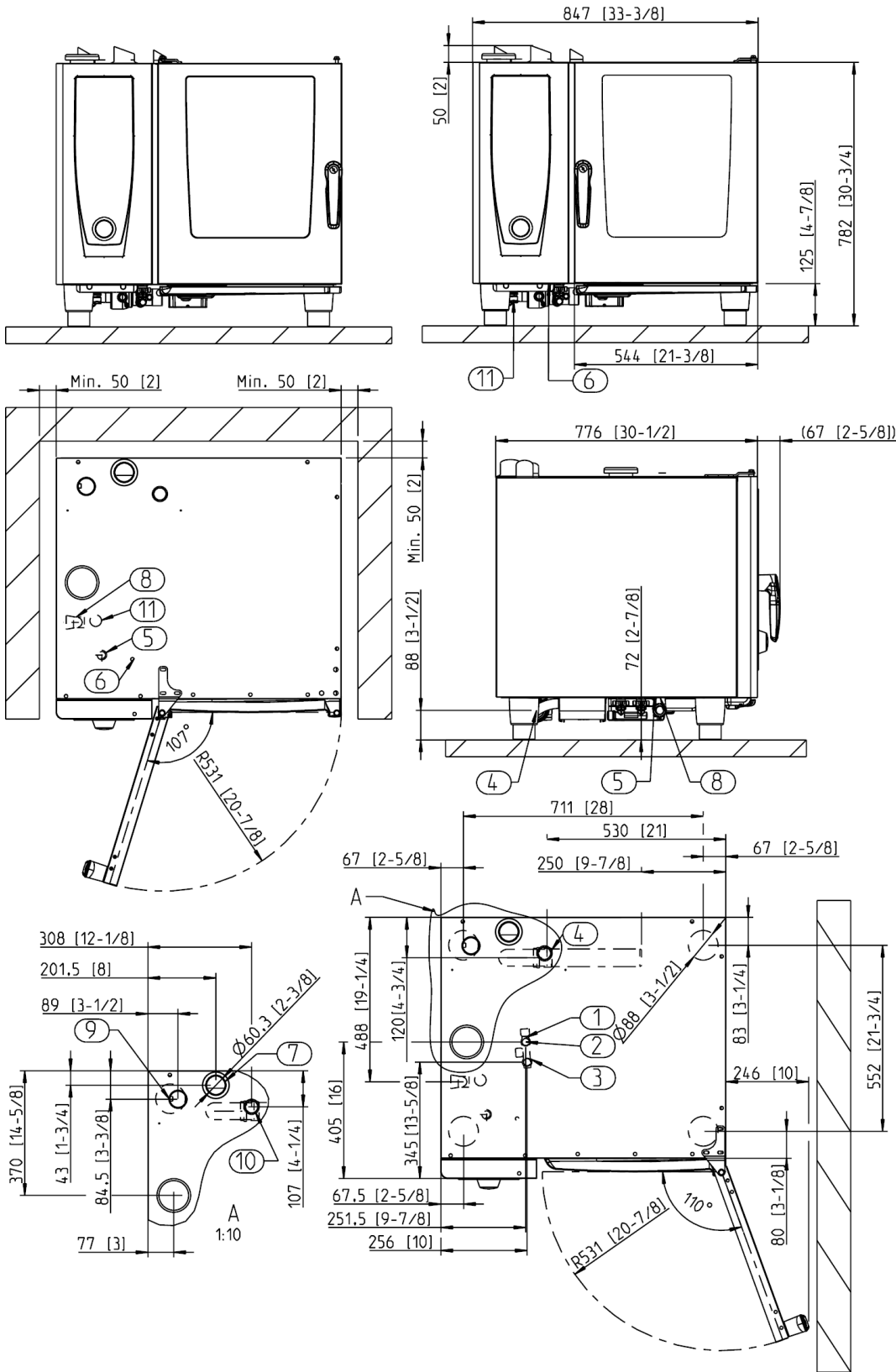

1. Common water supply (cold water) "Single" water connection as shipped 2. Water supply cold water / condensate "Split" water connection 3. Water supply cold / Treated "Split" water connection 4. Water drain 5. Electrical connection wire entrance 6. Chassis Ground connection 7. Steam Vent pipe DN 2 3/8" / 60 mm 8. Gas connection 3/4 NPT 9. Steam burner exhaust pipe 10. Hot-air burner exhaust pipe minimum distance 2" / 50 mm Left side clearance 20" recommended for servicing of unit without the ability to move unit while connected. Measurements in mm (inch)



Specification

Mon Sep 09 09:39:31 CEST 2019

CombiMaster® Plus CMP 61 G (6 x 12 x 20 inch/6 x 13 x 18 inch)

GAS OPTIONS

- Natural Gas
- Liquid Gas (LP)

ELECTRICAL CONNECTION ON GAS UNITS (all 60Hz) Special voltages available upon request

Voltage / breaker / running amps /

- 120V 1 Ph / 15 / 3.33 / comes with 5-15P cord and plug
- 208V 1 Ph / 15 / 1.92 / comes with 6-15P cord and plug -field retrofittable to 240 V / 15 / 1.67

ACCESSORIES

- Installation Kits – include quick disconnect gas, water and drainage connection
 - Gas 208/60/1 PH 8720.1560US
- RATIONAL Cleaner Tabs without phosphorous – guarantee maximum cleaning power 56.00.210A
- RATIONAL Rinse Tabs 56.00.211
- Electric descaler pump 60.40.497
- Descaler, 4x 1 gallon case 6006.0110US
- Certified installation by RATIONAL SERVICE-PARTNERS See document
- Preventative Maintenance Kits – door gaskets, air filters, interior light gasket, and light bulbs 87.00.520US
- Available stands – standard (stationary) and mobile (open or closed) See accessories brochure
- Mobile catering stand – especially for heavy mobile catering usage 60.30.890
- Catering kit for mobile catering stand – support frame and feet 60.73.111
- Mobile oven racks and Finishing® plate racks – easier operation of full loads See accessories brochure
- Run-in rail for mobile oven and plate racks 60.61.226
- Transport trolley for mobile oven and plate racks – standard and height adjustable See accessories brochure
- Stackable Combi-Duo kit, options: mobile or feet See accessories brochure
- Heat shield – for installation next to heat source (e.g. range, grill) 60.70.390
- Condensation breaker – to divert steam from the unit into existing hood system 60.72.591
- RATIONAL USB data-memory stick – for transferring cooking programs and HACCP data 42.00.162
- VarioSmoker – for a large variety of smoked products 60.73.010
- For ideal grilling, baking, roasting, frying, rotisserie, steaming, Finishing®, and much more See accessories brochure

FACTORY INSTALLED OPTIONS (special order)

- Left-hinged door natural gas
- Left-hinged door liquid gas (LP)
- Ethernet card and port – for easy connection of LAN cable
- Door safety lock – handle is turned left then right before the door can be opened
- Sous-Vide core temperature probe (externally attached)
- Externally attached standard core temperature probe
- Lockable control panel cover
- Control panel protection
- Mobile oven rack package (mobile oven rack + run-in rail)
- Unit with special hinging racks for bakeries and supermarkets
- Integrated fat drain (only in conjunction with UG II or US IV stands)
- Security and prison version

RATIONAL USA Inc.

1701 Golf Road, Suite C-120, Commerce
 Rolling Meadows, IL 60008
 Toll Free: 888-320-7274, Fax.: 847-755-9583

Visit us on the internet: www.rationalusa.com

We reserve the right to make technical improvements