

Platinum

Standard Features

- 36" wide sectional range with (2) 18" french hot tops available with a standard-oven base, convection-oven base, cabinet base, or as a modular unit (for mounting on countertop, refrigerated or freezer base)
- Two 35,000 BTU NAT (35,000 BTU LP) burner
- Battery spark ignition
- Removable steel plates with center surface temperature up to 900°F at the center
- High/Low setting
- 9-1/4" deep front rail
- Stainless steel front, sides, rear and exterior bottom
- Fully insulated lining and burner box
- 1-1/4" front gas manifold and 1" rear gas connection
- 5" high stainless steel flue riser
- Free battery-design assistance
- (3) years limited parts and labor warranty (reference <http://www.southbendnc.com/service.html> for limited warranty details)

Standard Features of Oven-Base Models

- 45,000 BTU NAT (45,000 BTU LP) oven with standing pilot
- Heavy duty, stainless steel door handle
- Porcelain enamel interior
- Oven racks (2 for standard oven, 3 for convection oven)
- "Insta-On" thermostat ranging from 175°F to 550°F
- Standard-oven interior is large enough (26" by 26-1/2") for sheet pans to fit either way
- Convection-oven models have 1/2 hp, two-speed blower

Standard Features of Cabinet-Base Model

- Stainless steel cabinet with removable doors that open from the center

- P36N-FF (Modular Mount)
- P36C-FF (Cabinet Base)
- P36D-FF (Standard-Oven Base)
- P36A-FF (Convection-Oven Base)



Model P36A-FF with optional 24" flue riser

Job
#

STANDARD CONSTRUCTION SPECIFICATIONS

Exterior Finish: Front, sides, rear and exterior bottom constructed of #3 polished 430 and 304 stainless steel.

Range: 36"-wide front-manifold sectional range with full-width graduated hot top with a 70,000 BTU NAT (70,000 BTU LP) burner. Removable steel plates and an operating surface temperature of up to 800°F (427°C).

Front Rail: 9-1/4" deep front rail.

Flue Riser: 5" high stainless steel flue riser

Battery: Unit can be in any position in a battery. If the unit is at the end of the battery, the end side will be solid (rather than have a coverplate over the end of the front manifold).

Legs: 6" stainless steel adjustable legs standard.

Model 36D: 45,000 BTU NAT (45,000 BTU LP) oven with standing pilot and thermostat range of 175°F to 550°F (79°C to 288°C). Porcelain enamel interior, measuring 14" high x 26" wide x 26.5" deep. Two racks with five-position side rails.

Model 36A: 45,000 BTU NAT (45,000 BTU LP) convection oven with standing pilot and thermostat range of 175°F to 550°F (79°C to 288°C). Porcelain enamel interior, measuring 14" high x 26" wide x 24" deep. Three racks with five-position side rails. Two-speed, 1/2 hp blower motor.

Model 36C: Stainless steel cabinet base with two removable doors that open from the center.



Models: P36N-FF P36C-FF P36D-FF P36A-FF

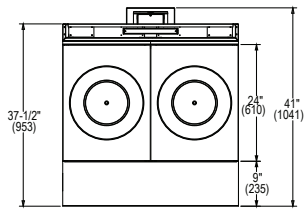

TOP VIEW

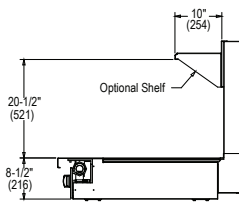

SIDE VIEW of MODULAR MODEL

Solid shelving has a depth of 10".

Tubed and Tray shelving have a depth of 11-1/8".

SHIPPING CRATE DIMENSIONS & WEIGHT					
MODEL	WIDTH	HEIGHT	DEPTH	VOLUME	WEIGHT
P36N-FF	45.5" (1156)	23" (584)	55" (1397)	33.3 cu ft (0.94 cu m)	346 lbs (156.9 kg)
P36C-FF	45.5" (1156)	45" (1143)	55" (1397)	65.2 cu ft (1.85 cu m)	523 lbs (237.2 kg)
P36D-FF	45.5" (1156)	45" (1143)	55" (1397)	65.2 cu ft (1.85 cu m)	629 lbs (285.3 kg)
P36A-FF	45.5" (1156)	45" (1143)	55" (1397)	65.2 cu ft (1.85 cu m)	682 lbs (309.3 kg)

Dimensions shown in inches and (millimeters)

Optional extra-deep flue riser (cooking area is same as for models with standard flue riser).

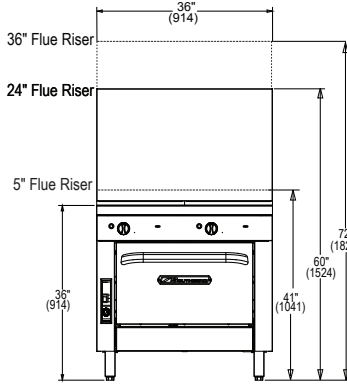

FRONT VIEW

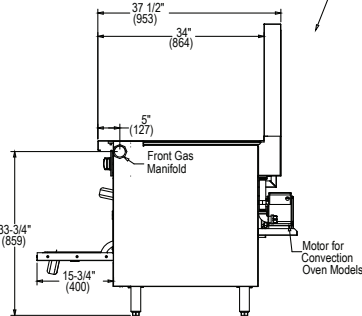

SIDE VIEW

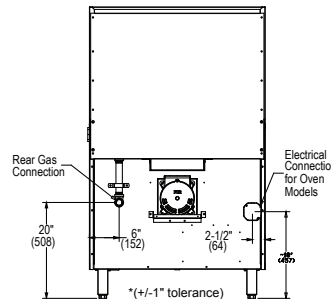

REAR VIEW

UTILITY INFORMATION

GAS: Each unit has a 1-1/4" front manifold that couples to the adjacent sectional unit(s), and a 1" rear gas connection with a male NPT connector. Minimum gas supply pressure is 7" W.C. for natural gas and 11" W.C. for propane.

All sectional units require a regulated gas supply (a pressure regulator must be ordered separately). If using a flexible-hose gas connection, the inside diameter of the hose must not be smaller than the connector on the unit and must comply with ANSI Z21.69, providing an adequate means of restraint to prevent undue strain on the gas connection.

ELECTRICITY: All oven models with optional electronic ignition require 50Hz or 60Hz single-phase power. 120V models have a 7-foot power cord with ground plug (5.9A for "A" models). 208/240V models have a terminal block for connection to a single-phase 208/240V source (2.7A for "A" models).

MODEL	GAS (BTU/HOUR)		ELECTRICITY (AMPS)	
	NATURAL	PROPANE	120V	208/240V
P36N-FF	70,000	70,000	-	-
P36C-FF	70,000	70,000	-	-
P36D-FF	115,000	115,000	0*	0*
P36A-FF	115,000	115,000	5.9*	2.7*

*Standing Oven Pilot Models

MISCELLANEOUS

- If casters are used with a flexible-hose gas connection, a restraining device should be used to prevent undue strain on the hose.
- Minimum clearance from noncombustible construction is zero (except there must be 2" clearance behind the blower motor of convection-oven models). Minimum clearance from combustible construction is 6" (152 mm) on sides and 6" (152 mm) on rear.
- Installation under a vented hood is recommended.
- Check local codes for fire and sanitary regulations.

NOTICE: Southbend has a policy of continuous product research and improvement. We reserve the right to change specifications and product design without notice. Such revisions do not entitle the buyer to corresponding changes, improvements, additions or replacements for previously purchased equipment.

OPTIONS and ACCESSORIES

- External pressure regulator
- Front rail options:
 - Cutouts in front rail for sauce pans
 - 7-1/4" deep front rail (to match old style sectional)
 - Square belly bar mounted on 7-1/4" deep front rail
- Casters (front two casters lock)
- Cable restraint kit (to restrict movement when on casters)
- 24" or 36" high flue riser
- Shelves on flue riser (one on 24" flue riser, one or two on 36" flue riser, 10" deep)
- Tray or tubular shelving (12" deep)
- Open-frame base with casters for battery
- Extra-deep rear-extending flue riser
- Stainless steel oven interior
- Salamander or cheesemelter mounted on 36" high flue riser
- Removable shelf inside cabinet
- Electronic oven pilot ignition (no charge)

**INTENDED FOR COMMERCIAL USE ONLY.
NOT FOR HOUSEHOLD USE.**



1100 Old Honeycutt Road, Fuquay-Varina, NC 27526
(919) 762-1000 www.southbendnc.com