

WORKTOP FREEZERS

VWF27HC

- 3 Year Parts & Labor Warranty Plus an Additional 2 Year Compressor Warranty
- Exclusive 2 Year Warranty on Santoprene Door Gaskets

VICTORY

ULTRASPEC®

STANDARD FEATURES

- Full Electronic Control
- High Performance, Balanced, Bottom-Mounted Refrigeration
- Anti-Corrosion Coated Evaporator Coil
- Stainless Steel Exterior / Aluminum Interior
- Cabinet back and bottom galvanized steel
- Stainless Steel 2 1/2" thick worktop with 4" high foamed in place backsplash
- Environmentally Safe R290 Refrigerant
- 2" Thick Foamed-in-Place Polyurethane Insulation
- Self-Closing Door(s) with 120° Hold Open Feature
- Santoprene Door Gaskets with Exclusive 2 Year Warranty
- 2 Epoxy Coated Shelves
- 6" Casters Standard, 2 with Brakes
- Cartridge Style Hinges
- 10' Cord and Plug (see electrical data for details)



VWF27HC

OPTIONS & ACCESSORIES

- Change Door Swing
- 3" Overall Height Casters (Set of 4)
- Secure-Temp 1.0™ Technology
- Extra Shelves
- 220/50Hz, 220/60 Hz Voltages



3779 Champion Blvd—Winston-Salem, NC 27105

PH: (888) 845-9800 - Fax: (800) 253-5168

sales@victoryrefrigeration.com www.victoryrefrigeration.com

CABINET CONSTRUCTION

Heavy duty construction includes stainless steel on front, sides, doors and grille. Cabinet interior is made from corrosion resistant aluminum. Stainless steel 2 1/2" thick worktop with 4" high foamed in place back-splash. Cabinet back and bottom are galvanized steel. Interior thermometer is standard.

Cabinet is insulated with foamed-in-place polyurethane insulation of 2" minimum thickness. Doors are mounted to cabinet on self-closing, cartridge style hinges with 120° stay open feature. A plug-in type vinyl magnetic gasket is attached to each door for positive seal. Convenient, contoured, pull handle is made of black anodized aluminum. Interior arrangement includes 2 steel wire epoxy coated shelves, adjustable in 1/2 inch increments.

ELECTRONIC CONTROL

REFRIGERATION SYSTEM

Refrigeration system utilizes R-290 refrigerant metered by expansion valve. Automatic (non-electric) condensate evaporator is standard. Interior forced air system, with high humidity evaporator coils, provides the ideal environment for food preservation.

Freezer temperature is held at 0°F

CHARACTERISTICS	VWF27HC
Width, Overall (in.)	27"
Depth, Overall (inc. Handles)	32.5
Depth, Door(s) Open 90°	55 1/4"
Height Overall (in.)	35.63
Capacity Net (cu ft)	5.8
No. Full Doors	1
No. of Shelves	2

ELECTRICAL DATA

Cabinet Voltage	115/60/1
Total Amperes	6.0

NOTE: Plug style, voltage and full load amps may vary depending on certain options selected such as optional voltages and compressor upgrades.

REFRIGERATION DATA

Condensing Unit Size	1/2 HP
Refrigerant	R-290

CRATED WEIGHT

162 LBS

* Remote units use R-404A refrigerant standard and come with 6" legs

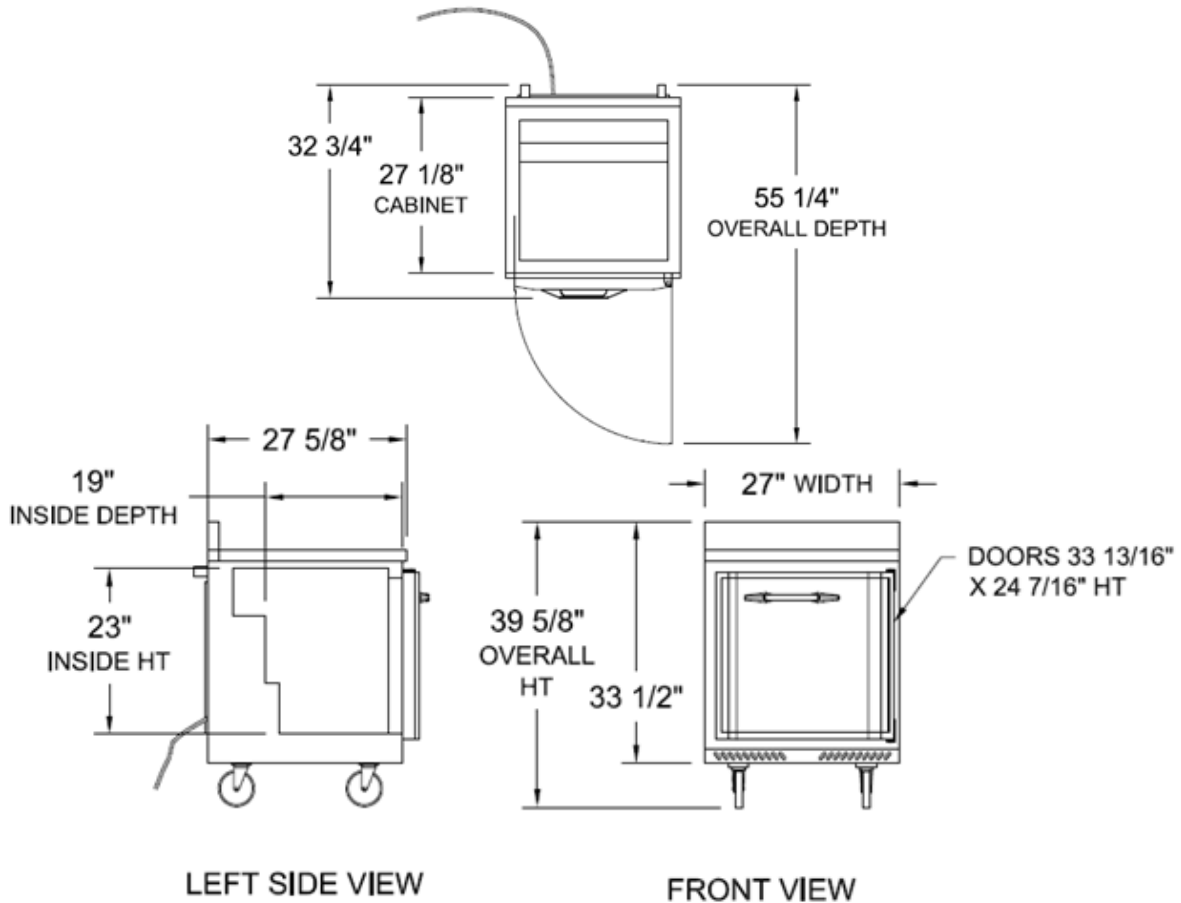

We reserve the right to change specifications and product design without notice. Such revisions do not entitle the buyer to corresponding changes, improvements, additions or replacements for previously purchased equipment. Dimensional tolerances +/- 1/4". Metric dimensions (MM)