

# Carts & Kiosks - Merchandising Carts

Contact Your Vollrath Sales Representative for Custom Carts & Kiosks!

Carts & Kiosks—Merchandising Carts

**Option:** Signage for wrap-style and tubular canopy. Vinyl graphics on (artwork provided by customer)

**Standard:** Polyform or laminate countertop (laminates color must be specified)

**Standard:** Available in cost effective WCM (wood composite material) or lightweight ACM (aluminum composite material)

- Standard ACM carts are available in black, white, or silver
- Standard WCM carts are available in Harvest Cherry, Natural Maple, Castle Oak, or Black
- Matching toe kick



**Option:** Track lighting for canopies (Requires at least 120V 15 AMP service)

- 15 amp 120V electrical service (NEMA 5-15P)
- 20 amp 120V electrical service (NEMA 5-20P)
- 30 amp electrical service (NEMA #L14-30P)
- 60 amp electrical service (plug #460P-12W)
- 100 amp electrical service (plug#4100P-12W)

**Option:** Heavy duty paddle latch doors (qty. 2 for 6', qty. 5 for 8', qty. 6 for 10')

For WCM (Wood Composite), carts add the letter "W" to the end of the model number. See Autoquotes for pricing information.



Item 75675 shown with modular options

**Option:** Wrap-style canopy with two adjustable poles (color matching base)

**Option:** 1" (2.5cm) bumper (all sides)

**Standard:** Heavy-duty casters

**Option:** Base color option

- laminated (one color) on 3 sides
- painted base (one color) on 3 sides
- digital graphics (artwork supplied by customer) on 3 sides

**Option:** Countertop grommet holes

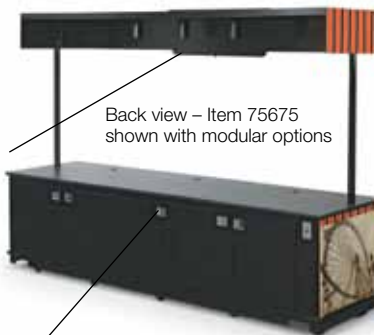

Item 75675

**Standard Feature** (Not Shown)

- Open storage (server side)

**Optional Features** (Not Shown)

- Adjustable undercounter shelving
- Umbrella

- Aluminum tubular canopy (bulkhead) with two adjustable poles (powder coated - color specified)



Setting the Standard™

For more details on ACM/WCM, visit [www.vollrathco.com](http://www.vollrathco.com)

# Carts & Kiosks - Merchandising Carts

Merchandising Carts — Dimensions shown in IN (CM)

## 75674 / 75674W

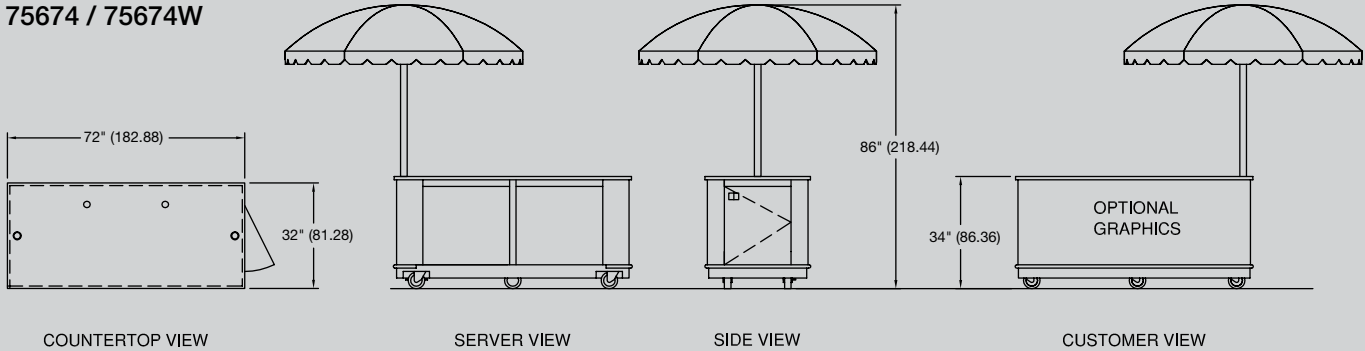

## 75690 / 75690W

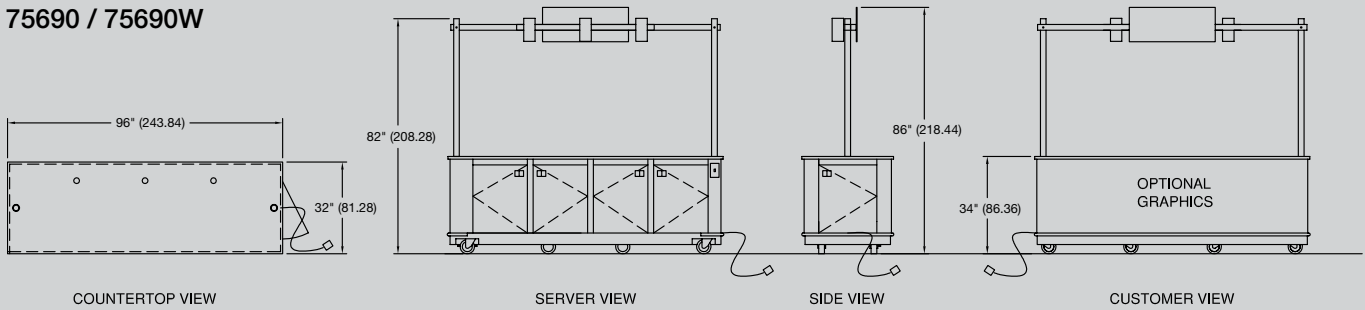

## 75675 / 75675W

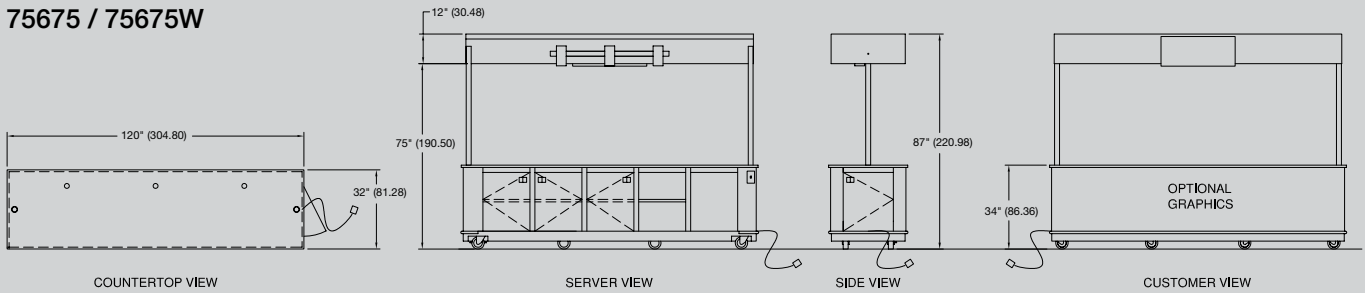

Receptacles



The Vollrath Company, L.L.C.  
 1236 North 18th Street  
 Sheboygan, WI 53081-3201 USA  
 Customer Service: 800.628.0830  
 Equipment Service: 800.628.0832  
 Main PH: 920.457.4851  
 Fax: 920.459.6573  
 Form L35703 Rev 7/10



Setting  
 the Standard™