

P300 Series U-Boat with Plastic Deck

ITEM NO. _____

QUANTITY NO. _____

JOB NO. _____

SPEC NO. _____



P300-60PU

SPECIFICATIONS:

- Light weight, easy to clean, gray Plastic Deck will not rust, discolor or warp. Ideal for indoor/outdoor use. Virtually Maintenance free. End Handles and Frame constructed of all welded steel.
- Narrow 18" (457 mm) width, designed for use in busy aisles. Anti-skid deck surface and two removable high-end handles prevent merchandise from sliding .
- Maneuvers easily on two 8" stationary center load wheels and four 4" swivel end casters, P300-60 all rubber and P300-60/PU all polyurethane. Six wheel design allows cart to swivel within its own radius.

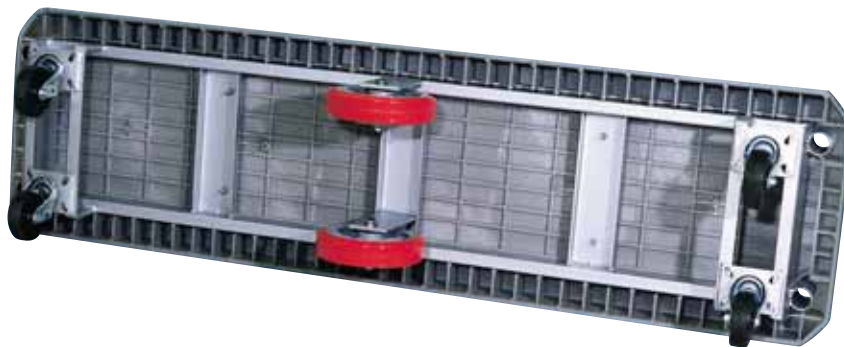

**Reinforced Steel
Undercarriage**

***Lightweight!
Easy to Maneuver!***

P300 Series U-Boat with Plastic Deck



439 Oak Street • Garden City, NY 11530 • Tel: 1-800-444-3595 • Fax: 516-222-0371
www.winholt.com • sales@winholt.com

NEW YORK • GEORGIA • TEXAS • CALIFORNIA



ITEM NO. _____
 JOB NO. _____
 SPEC NO. _____

P300 Series U-Boat, Plastic Deck

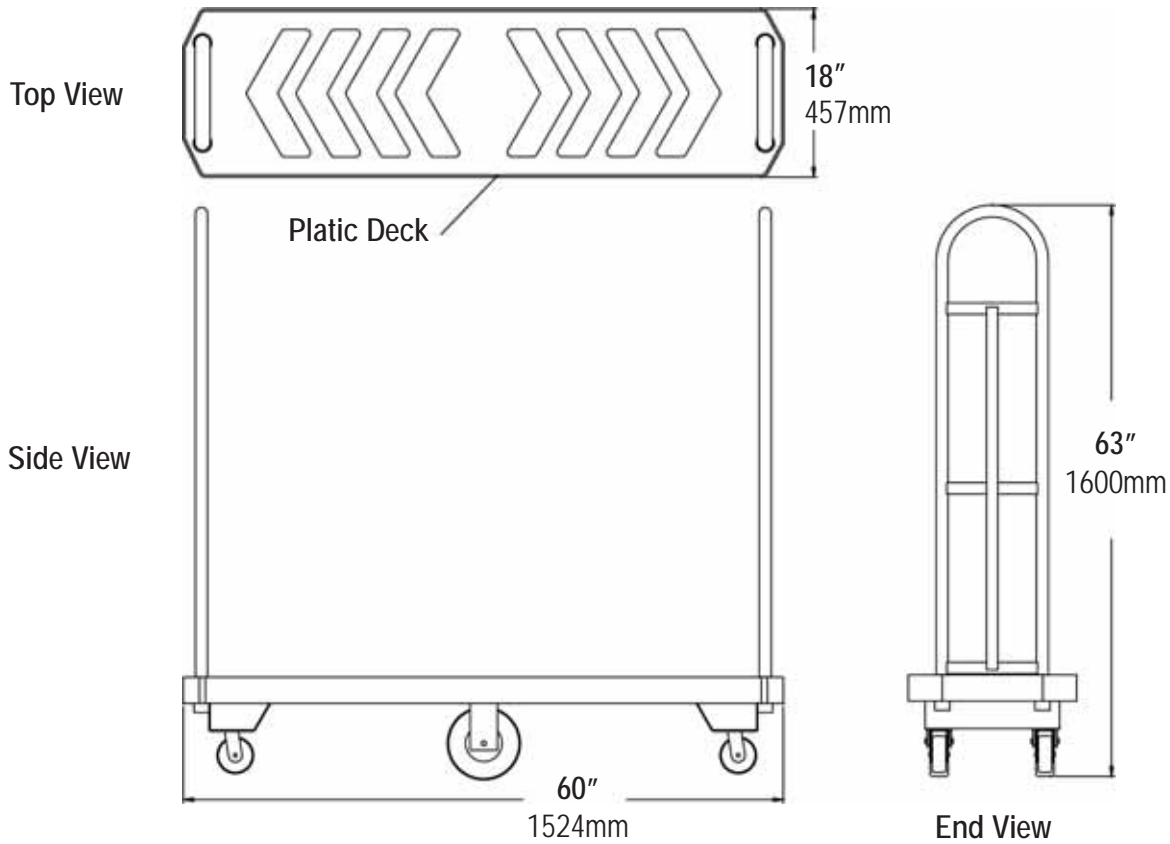

Model Number	Ordering Number	Overall Dimensions						Capacity		Approx. Ship Weight	
		Width		Length		Height		(lb)	(kg)	(lb)	(kg)
		(in)	(mm)	(in)	(mm)	(in)	(mm)				
P300-60	185009	18	457	60	1,524	63	1,600	1,500	680	116	53
P300-60 / PU	185017							1,650	748	124	56
Replacement Caster Information - Model P300-60											
732	123078	Swivel Plate Caster with 4" Rubber Wheel									—
712	128750	8" Mold-On Rubber Center Wheel									—
Replacement Caster Information - Model P300-60/PU											
7130	122462	8" Polyurethane Center Wheel									—
7351	123211	Swivel Plate Caster with 4" Polyurethane Wheel									—
7125	122403	4" Polyurethane Wheel									—

Freight Class: 70

Win-Holt Equipment Group is a leading manufacturer of material & food handling equipment. Since 1946, retailers and restaurant chains have trusted Win-Holt's equipment to ensure increased productivity and efficiency in their operation. Multiple locations reduce logistics and transportation costs. All Win-Holt associates are dedicated to customer satisfaction.

For general sales and engineering information only. All units are subject to change without notice. Please consult factory for certified specifications.

439 Oak Street • Garden City, NY 11530 • Tel: 1-800-444-3595 • Fax: 516-222-0371
 www.winholt.com • sales@winholt.com

NEW YORK • GEORGIA • TEXAS • CALIFORNIA