

Universal Carts

ITEM NO. _____

QUANTITY NO. _____

JOB NO. _____

SPEC NO. _____

SPECIFICATIONS:

All Universal Carts

- The carts are constructed of all-welded aluminum tubing. Will not rust like wire carts.
- Recessed Shelves hold products more securely.
- Carts maneuver easily on four heavy duty polyurethane 5" stem casters.

UNAL-4, UNAL-6, UNAL-7-32, UNAL-8

- Hold all sizes of trays, pans, or lugs up to 18"x26". Carts allow for easy packing and unpacking.

- The UNAL-7-32 (seven shelves), offers double capacity, with shelves holding two 10" (254 mm) or 12" (305 mm) platters side by side.
(Note: The UNAL-8 does not accommodate lugs).

UNAL-5-WEG and UNAL-8-WEG

- Narrower design makes it perfect for trays and pans.

Ideal for all your product handling needs!



UNAL-6



UNAL-8-WEG

LABORATORY CERTIFICATION AND APPROVAL SYMBOLS:



Founded in 1946

20 Crossways Park North • Woodbury NY 11797 • Tel: 1-800-444-3595 • Fax: 516-921-0538
www.winholt.com • sales@winholt.com

NEW YORK • PENNSYLVANIA • TEXAS • CALIFORNIA

ITEM NO. _____
 JOB NO. _____
 SPEC NO. _____

Universal Carts

Universal Carts

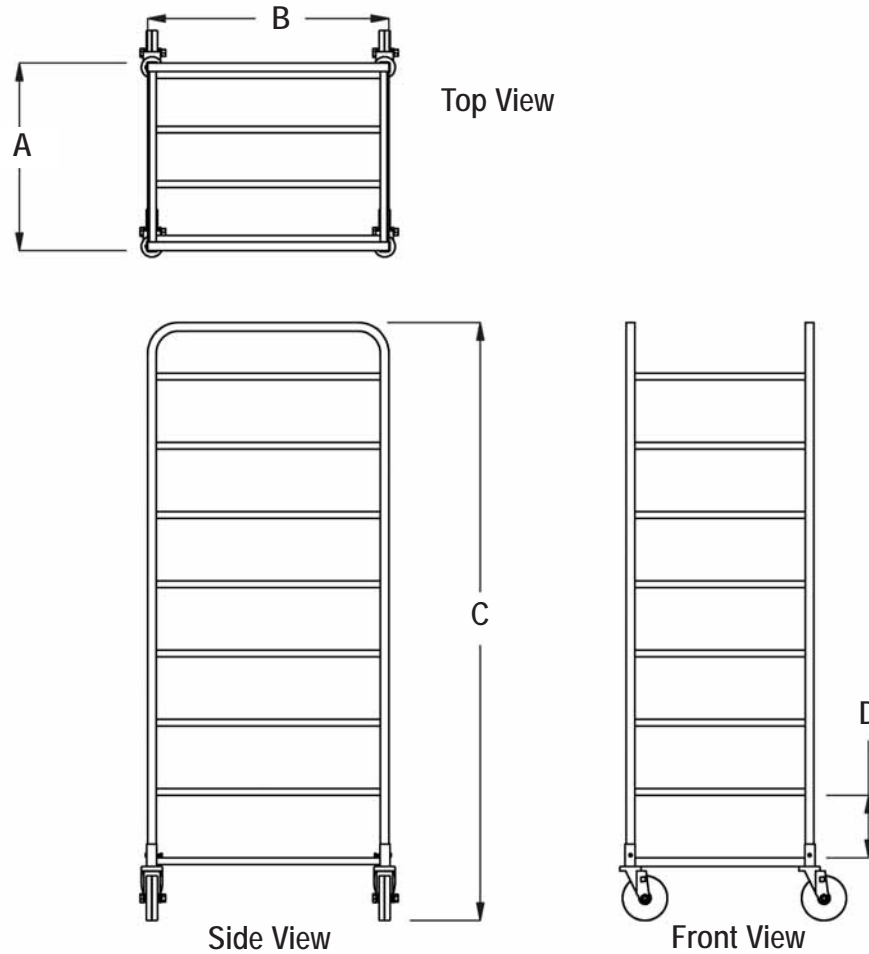

Model Number	Ordering Number	Overall Dimensions						# of Shelves	D		Weight Capacity		Approx. Ship Weight	
		A Width		B Length		C Height			Space Between Shelves		(lb)	(kg)	(lb)	(kg)
		(in)	(mm)	(in)	(mm)	(in)	(mm)		(in)	(mm)				
UNAL-4	103616	21	533	27	686	43	1,092	4	10	254	800	363	26	12
UNAL-6	103691					67	1,702	6	10	254			32	15
UNAL-7-32	103747	28	711	32	813	68	1,727	7	9	229	1,200	544	65	29
UNAL-8	103771	21	533	27	686	67	1,702	8	7	178	800	363	38	17
UNAL-5-WEG	103659	16	406	32	813	42	1,067	5	7	178	800	363	30	14
UNAL-8-WEG	103798					67	1,702	8					40	18
Replacement Caster Information														
757	123684	Swivel Square Stem Caster with 5" Polyurethane Wheel										—		
7112	122180	5" x 1 1/4" Polyurethane Wheel										—		

Freight Class: 250

Winholt Equipment Group is a leading manufacturer of material & food handling equipment. Since 1946, retailers and restaurant chains have trusted Winholt's equipment to ensure increased productivity and efficiency in their operation. Multiple locations reduce logistics and transportation costs. All Winholt associates are dedicated to customer satisfaction.

For general sales and engineering information only. All units are subject to change without notice. Please consult factory for certified specifications.

20 Crossways Park North • Woodbury NY 11797 • Tel: 1-800-444-3595 • Fax:
 516-921-0538 www.winholt.com • sales@winholt.com

NEW YORK • PENNSYLVANIA • TEXAS • CALIFORNIA